

# Complete Touchless Sanitary Cabinet & Modular Collection



AIR



WATER



SOAP

Demand for touchless sanitary products is soaring as architects and designers look for practical ways to improve hygiene in public restrooms in order to prevent the spread of germs. Stern's Complete Cabinet & Modular Collection are practical systems that will ensure a consistently hygienic touch free flow of users in high traffic commercial washrooms. Installing touchless faucets, soap or foam dispensers, hand dryers and even paper towel dispensers behind the mirror provides not only a germ-free environment but no more hand drying queues or dripping hands on the way to the dryers. Everything is touch free and above the sink so the whole hand washing process is quicker and cleaner since everything is now above the basin and not scattered around the wall space. Maintenance time also decreases therefore creating a decrease in maintenance costs.



# SWAR

Stern's Complete Touchless Sanitary Cabinet; the SWAR (soap-water-air-revolution) is a complete sanitary cabinet with a lockable mirror that contains electricity powered, touch free faucet, touch free soap dispenser, thermostatic mixing valve, high speed hand dryer and optional a paper towel holder. Everything is installed inside the cabinet prior to delivery for easy installation onsite. LED pictograms on the mirror provide intuitive user guidance and a remote control is available to customize settings, so you can control the soap dosage and water flow for even more savings.

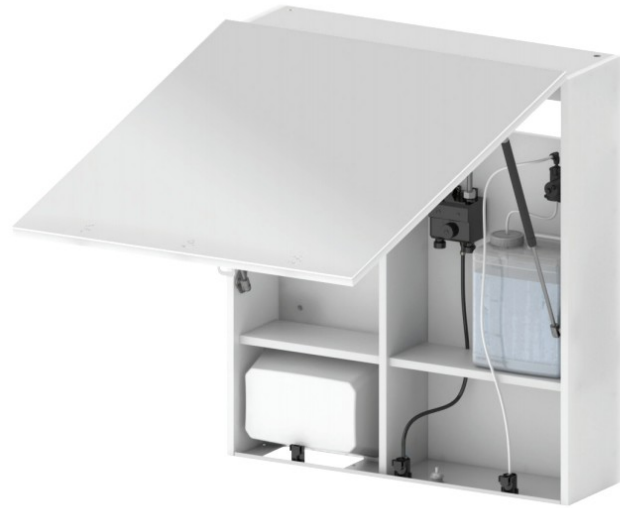

- Eliminates messy, slippery floors and hand drying queues
- Saves time and money by reducing maintenance in commercial facilities
- Ideal touch free soap-water-air cycle
- Helps prevent cross contamination
- Reduces water and soap consumption
- Can be used with any non-proprietary soap of the correct viscosity
- Drying time: less than 30 seconds
- Remote controls to adjust soap dosage, customize the faucet settings and select light color and/or sequence of the LED pictograms

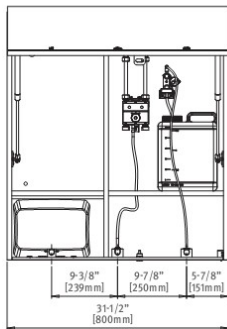
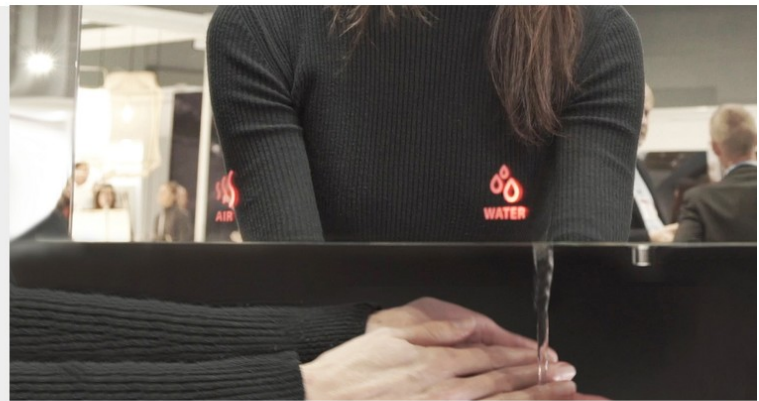

**SWAR**  
PN 280460

- Touch free faucet
- Touch free soap dispenser
- Mixing valve
- High speed hand dryer
- LED pictograms for intuitive user guidance
- Remote controls to customize settings
- Powered by 12V transformer

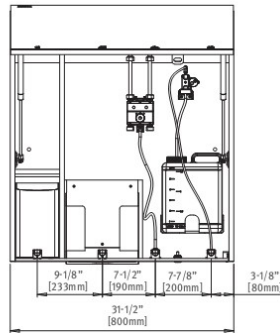

**SWAR P**  
PN 280470

- Touch free faucet
- Touch free soap dispenser
- Mixing valve
- High speed hand dryer
- Paper towel holder
- LED pictograms for intuitive user guidance
- Remote controls to customize settings
- Powered by 12V transformer

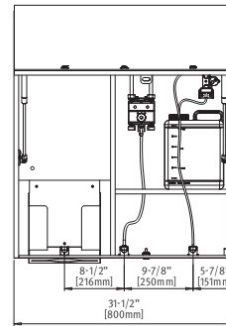

**SWAR PA**  
PN 280462

- Touch free faucet
- Touch free soap dispenser
- Mixing valve
- Paper towel holder
- LED pictograms for intuitive user guidance
- Remote controls to customize settings
- Powered by 12V transformer

# SWA HI-SPEED MODULE

Stern's Modular Solution; the SWA (soap-water-air) is a modular system for integration behind the mirror or wherever you choose, that can be put together as you wish, according to the needs of your specific project. This system includes a high speed hand dryer, thermostatic mixing valve, touch free faucet, liquid soap dispenser and even an optional soap level indicator lamp. The modular system can be put together with any combination of the aforementioned touch free products creating your own customized solution according to your own specifications either behind a mirror or elsewhere.

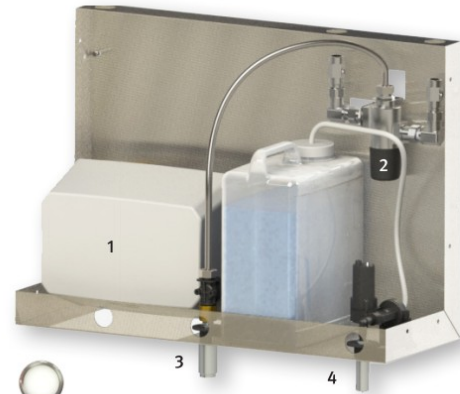

Complete system including high speed hand dryer (1), thermostatic mixing valve (2), touch free faucet (3) liquid soap dispenser (4) and optional lamp soap level indicator (5)

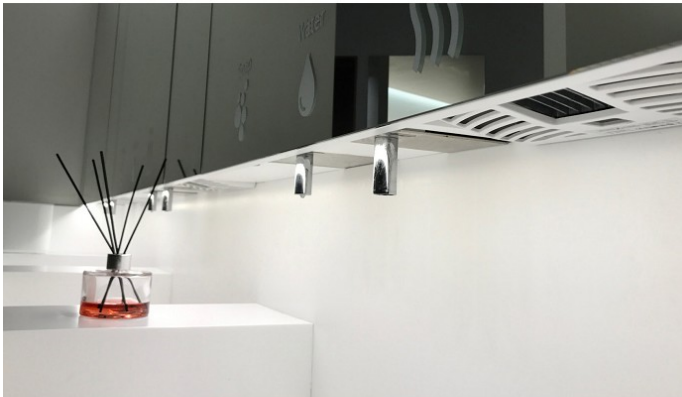

- Ready to be integrated behind the mirror for a clear, minimalistic design
- Eliminates messy, slippery floors and hand drying queues
- Reduces the amount of labor for commercial facilities maintenance
- Easy installation with a stainless steel frame to be fixed to the wall
- Ideal touch free soap-water-air cycle
- Helps prevent cross contamination
- Reduces water and soap consumption
- Can be used with any non-proprietary soap of the correct viscosity
- Drying time: less than 30 seconds

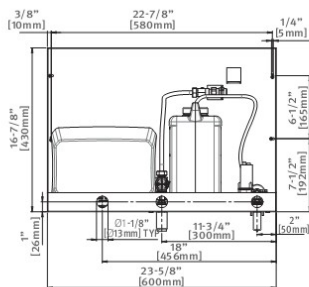

PN 280410  
 12V Transformer



Modular system including touch free faucet (2) and liquid soap dispenser (3)

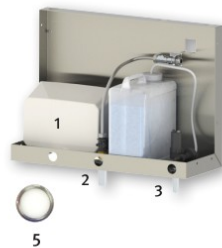

Modular system including high speed hand dryer (1), touch free faucet (2) and liquid soap dispenser (3) and optional lamp soap level indicator (5)

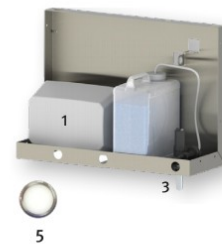

Modular system including high speed hand dryer (1) and liquid soap dispenser (3) and optional lamp soap level indicator (5)

# BTM SOAP DISPENSER

Touch free electronic soap or foam dispenser for integration behind the mirror

- Easy to install and refill
- Helps prevent cross contamination
- Drastically reduces soap consumption
- Peristaltic pump that prevents contamination and back flow
- Can be used with any non-proprietary soap or foam of the correct viscosity
- Soap priming operated by remote control or by easy-to-use manual refill button
- Accurate soap or foam dosage, adjustable by remote control
- Matching IR operated faucet

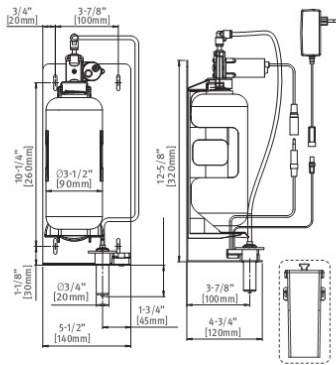

**BEHIND MIRROR SD**  
 Delivers liquid soap.  
 Battery box for six (6) D batteries/  
 12V Transformer  
 PN 280210 - Battery Version  
 PN 280200 - 12V Transformer

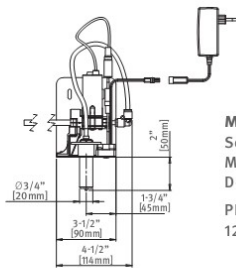

**MF BEHIND MIRROR SD**  
 Soap dispenser to be used with Stern's  
 Multifeed kits for multiple refill.  
 Delivers liquid soap.  
 PN 07292223  
 12V Transformer

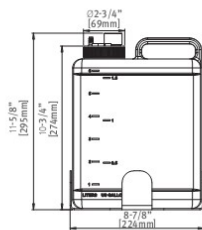

**MULTIFEED KIT**  
 This version allows multiple soap dispenser  
 refill (up to 6 dispensers)  
 with a single 1.6 US  
 Gallons (6 liters) tank.  
 PN 07220096



# BTM FOAM DISPENSER

Touch free electronic soap or foam dispenser for integration behind the mirror

- Easy to install and refill
- Helps prevent cross contamination
- Drastically reduces soap consumption
- Peristaltic pump that prevents contamination and back flow
- Can be used with any non-proprietary soap or foam of the correct viscosity
- Soap priming operated by remote control or by easy-to-use manual refill button
- Accurate soap or foam dosage, adjustable by remote control
- Matching IR operated faucet

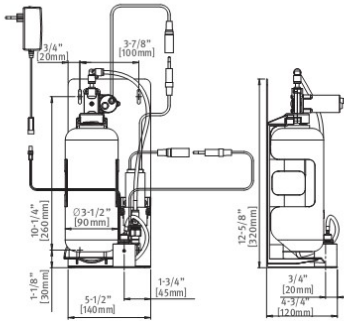

**BTM FOAM E**  
Delivers foam soap  
12V Transformer  
PN 280250

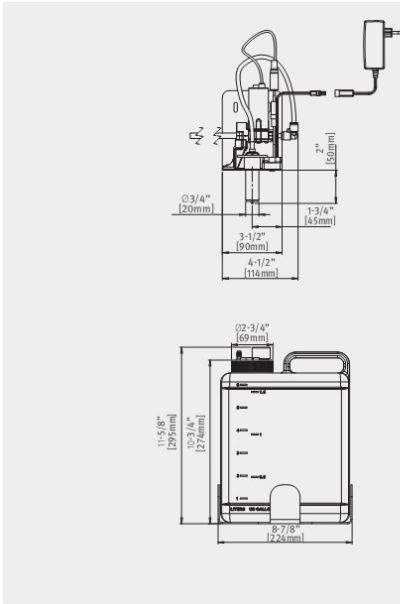

**MF BEHIND MIRROR FOAM**  
Soap foam dispenser to be used with  
Stern's Multifeed kits for multiple refill.  
Delivers foam soap.  
PN 07292270

**MULTIFEED KIT**  
This version allows multiple soap dispenser  
refill (up to 6 dispensers) with a single 1.6 US  
Gallons (6 liters) tank.  
PN 07220096



# BTM FAUCET

Electronic wall mounted faucet for integration behind the mirror

- Drastically reduces water consumption
- No physical contact. Helps to protect users against cross contamination
- Sensor settings adjustable by remote control
- Easy installation behind the mirror
- Matching IR operated soap dispenser

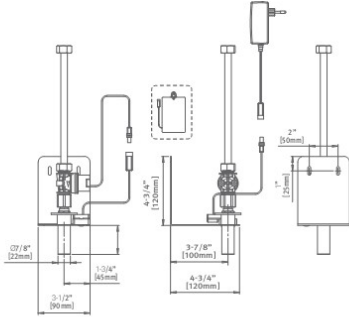

PN 280300  
9V transformer  
PN 280310  
6 x 1.5V AA Batteries



# BTM PAPER TOWEL HOLDER

Paper towel holder for integration behind the mirror as part of the SWA electronic wall mounted system. Space saving and functional solution with easy installation. Accommodates standard paper towels from your favorite brands (paper towels not included).

- Material - Stainless Steel AISI316
- Dimensions - 260mm x 300mm x 116mm

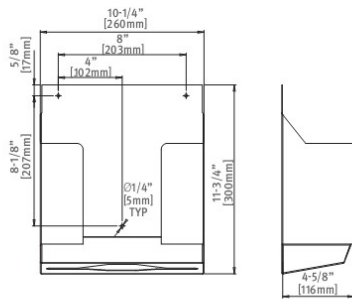

**PAPER TOWEL HOLDER**  
Stainless Steel AISI316  
paper towel holder  
PN 03300018



# REMOTE CONTROLS

Stern's soap dispensers are installed in multiple locations around the world, each with different requirements. The remote controls provide customization options for a wide range of settings.

## SOAP & WATER REMOTE CONTROL

Enables customization of settings for liquid or foam soap dispensers as well as Stern's touch free faucets.

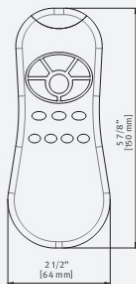

PN 07100014

## LIQUID SOAP DISPENSERS REMOTE CONTROL

Adjustable settings:

- Soap dosage • Temporary shut off • Soap tank refill
- Reset to factory settings

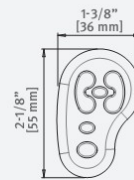

PN 07100008

## FOAM SOAP DISPENSERS REMOTE CONTROL

Adjustable settings:

- Soap dosage • Air quantity • Temporary shutoff function
- Soap tank refill • Reset to factory settings

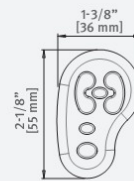

PN 07100009





**STERN ENGINEERING LTD.**

USA:	FACTORY:
777 Passaic Avenue	15 Gan Rave Blvd.
Clifton NJ, 07012	8122214, Yavne, Israel
Tel: +1-973-773-8011	Tel: +972-8932-6000
Toll Free: +1-800-436-4410	info@sternfaucets.com
sales@sternfaucets.com	

[www.sternfaucets.us](http://www.sternfaucets.us)  
[www.sternfaucets.com](http://www.sternfaucets.com)  
[www.sternfaucets.es](http://www.sternfaucets.es)