

PRODUCT RANGE 2021/22

starmix

Made with Passion. Made for you.

Sanitary | Hand Dryers | Hair Dryers | Hospitality | Disinfection



100

1921
2021

ELECTROSTAR
STARS

FOR THE **SANITARY SECTOR**

100 years of competence in air and flow technology - appliances for hotels, swimming pools, fitness studios, spas, saunas, public facilities, trade and industry.

Anniversary

We celebrate together - 100 years of ELECTROSTAR

With 100 years of expertise in vacuum cleaners and blowers, we are one of the oldest companies in the industry. Today we work with about 200 employees every day to develop and produce innovative, efficient and high quality products for customers all over the world.

We want to celebrate this great anniversary with you

For this reason, not only limited anniversary products await you this year, but also attractive raffles and unique events to thank all our customers and partners.

1921
2021



ELECTROSTAR

Welcome to the next 100 years.

Even though the history of our medium-sized family business began in the golden twenties, the times were truly not always golden. We have learned one thing above all in the past: to look ahead. Innovative spirit and uncompromising quality have not only been our core values since 1921, but also the standard we set for ourselves. We also work every day to ensure that customer intimacy and openness can be felt in every one of our products.

Our Electrostar family has grown considerably in recent years: Haaga sweeping systems have been integrated into Electrostar. We took our long-time Dutch sales partner Equi into the group of companies. And we have entered into a strategic partnership with Producteers. Since 2019, we have been shaping our future at our new location in Ebersbach, whose modern infrastructure provides all the necessary conditions for further successful corporate development. So we celebrate our anniversary not only with a strengthened team and in new premises. This year, we will also be accompanied by a whole fireworks display of new products - each of which is even better tailored to your needs.

We are looking forward to the next 100 years full of challenges, together with our customers, colleagues and partners.

Sincerely yours



Roman Gorovoy
Managing Director



For more information
visit our website:

www.starmix.de/en/100-years-electrostar



Limited Anniversary Products

The devices of the anniversary edition are equipped with additional features. Those who can secure one of the anniversary products will receive the limited edition with unique features and limited design.



Raffles with jackpot chance

In our newsletter we keep you informed about the latest promotions. Here you will be the first to know about our great anniversary raffles and at the end of the year you will have the chance to win the main prize - it's worth participating!



Exclusive events

The dialog with our customers and partners must not be neglected this year either. In exciting expert presentations you can expect the latest information on new products and top-class speakers on industry-relevant topics - there's something for everyone.



Exciting cooperations

On our social media channels you can expect exciting cooperations and projects with professionals from the trade. In addition, you can always get interesting insights into Electrostar on Instagram, Facebook and Co.

CONTENTS

04 100 years of ELECTROSTAR

06 Disinfectant dispensers

10 The solution for your sanitary area

11 The Greenstar

12 Hand Dryers

13 Highspeed Hands-in XT 3001

15 Electrical Hand Dryers vs. paper towels

16 Highspeed Compact „AirStar“ T-C1

19 Planning with foresight

22 Vandal-proof dryer T-C1 M & T-C1 Mw

23 Vandal-proof dryer XT 1000 E & XT 1000 ES

24 Comfort dryer TT 1800 E

26 Basic dryer T 70 E

28 Hand Dryers – decision support

30 Hair Dryers

32 Highspeed Compact „Airstar“ TB-C1

33 Highspeed Compact „Airstar“ TH-C1 & H-C1

35 Vandal-proof dryer TH-C1 Mw & H-C1 M

37 Basic dryer TH 70 Z

38 Hair Dryer – decision support

40 Hand-held Hair Dryers

41 HF-series (hotel special)

42 TF-series

43 HFTW-series

45 HF-series

46 Special hand-held hair dryer HFXW 20

47 Planning guides Hair Dryers

48 Hand-held Hair Dryers – Decision support

50 Accessories for hand-held Hair Dryers

51 Equipment for the hotel bathroom

52 Grab bar, fixation, shower seat

54 In-Room accessories hotel

55 Water kettle, tray

56 Ironing board

57 Iron, hooks

58 Floor cleaning

59 Dry vacuum cleaner TS 714 RTS HEPA

60 Broom haaga 137 accu

61 Explanation pictograms

62 Explanation of certification marks

63 Contact

Anniversary

We are looking back - at 100 years of ELECTROSTAR



1921

Robert Schöttle sen. founds in Stuttgart the "Electrotechnical Special factory for vacuum cleaners and Blower".

1925

The company gets its current name "ELECTROSTAR". The first warm air hand dryer in the world is being developed.

1928

Electrostar moves to Reichenbach with already 30 employees.

1933

The first stem sucker comes on the market. Also kitchen machines for kneading and stirring are produced.

1921 - 1939

1940 - 1949

1938 - 1945

The production is concentrated on the manufacture of special parts for the ball bearing industry, machine tools and special motors. The production of vacuum cleaners and blowers is resumed at the end of May 1945.

1948

"The Starmix", the first high-speed food processor, can conquer the market. It becomes a symbol of the German economic miracle in the 50s and establishes the brand name "starmix".



1953

Peter Kotthaus joins the company. The "Piccolo" is a million-dollar hit. It combines a food processor, vacuum cleaner and floor polisher in one device. Already more than 600 employees are employed.

1955

With the hand and floor vacuum cleaners "Starboy" and "Starmaster" powerful devices are launched on the market.

1959

Shortly before his 71st birthday, the company founder dies. Hans Schöttle (son) and Peter Kotthaus (son-in-law) take over the management.

1950 - 1959

1960 - 1969

1960

The designer Graf Goertz creates "The Young Line", consisting of high-quality electrical household appliances.

1962 - 1963

The MX4 kitchen machine sets new standards with its concentric drive for mixing cups and accessories.

1968

With the warm-air hand dryer T5 starmix becomes the long-time market leader in this segment. Due to the high degree of awareness of the starmix brand, all ELECTROSTAR products receive the starmix signet.



1972

The SM6 introduces a new and long successful concept for floor vacuum cleaners, which serves as a model for many.

1977

With Robert Schöttle junior, the 3rd generation takes over responsibility in the company.

1978

The robust HG6 expands the concept of all-purpose units, which can vacuum wet and dry and are equipped with a newly developed electromagnetic filter cleaning system.

1970 - 1979



1994

The ISB leaf and suction blower "PICKUP" is a great success. Within 2 years the turnover doubles.

1996

Electrostar withdraws from the highly competitive segment of small electrical household appliances and concentrates on its core competencies "suction and blowing".

1997

Starmix intensifies its export business in the Middle and Far East and starts a joint venture in Beijing for the production of a hot air dryer series, which is still successfully marketed worldwide.

1990 - 1999



2011

The Algo-Group complements the range of services by purchasing Haaga Kehrssysteme GmbH.

2013

The ISP iPulse suction cup series sets the again high standards through suction power and protection of the user against dangerous dusts.

2015

The NSG uClean vacuum cleaner series follows the HS and GS vacuum cleaners, which have been successful for many years, and provides fresh wind in the starmix vacuum cleaner portfolio with new features.

2017

The new "Highspeed Compact Class" dryer line will be launched this spring. In the fall, the popular iPulse series of vacuum cleaners is relaunched.

2019

After 90 years at the Reichenbach site, Electrostar moves together with its sister company Haaga, to the neighboring Ebersbach an der Fils. The move optimizes processes and procedures in the company and has a lasting impact on the corporate culture. Also this year, Electrostar takes over the long-time sales partner EQUI from the Netherlands in order to expand the market position there as well.

2010 - 2019

1980 - 1989

1980 - 1981

Robert Schöttle is nominated managing director.

1982

The T7 in a robust aluminum housing is the first vandal-proof hand dryer from ELECTROSTAR.

1984

starmix becomes the market leader with the universally applicable ZYKLON vacuum cleaner HG8, with its flow-optimized tangential air intake and the modular platform concept.

1985

The warm air dryer program is the widest range of products in the industry.



2000 - 2009

2000

The new trade and industrial vacuum cleaner IS is presented.

2003

With the Gorovoy family (Algo-Group) a strategic partner in Eastern Europe is found. In three stages, the Algo-Group takes over all shares of the founding family Schöttle in three stages until 2007.

2006

Electrostar acquires the Chinese company Huan Ju and uses it to establish the subsidiary BESEA in China.

2008

The company will operate under the name Electrostar GmbH. Roman Gorovoy will be the operative managing director. Robert Schöttle becomes chairman of the advisory board.

2009

The company is investing more and more in Modernization of the production.



2020 - 2021

2020

What belongs together finally comes together - in the fall, Starmix and Haaga merge. In addition, a strategic partnership is formed with the Producteers Group. With the combined expertise of both brands, the new decade is full of drive.

2021

This year Electrostar celebrates its 100th anniversary. This stands for 100 years of specialists in the field of vacuum cleaners and blowers, 100 years of quality products and 100 years made for you!

For this occasion there will be some specials this year. More detailed information can be found on page 2.



**2-in-1 device:**

The free-standing disinfector dispenser can be easily converted into a tabletop disinfector dispenser in just a few steps and can therefore be used flexibly.

**Easy cleaning:**

The drip pan of the dispenser is removable and easy to clean thanks to the smooth surface.



Disinfection Station - Dispenser & Gel.

Highest demands on hygiene and design

The combination of shapely design and caring hygienic substances. The new freestanding hand disinfectant dispenser made of refined aluminium in highest quality. Robust, stable and easy to clean. The dispensing of the disinfectant is contactless via sensor control.

Hygiene, care and design in one - what more could you want.



★ All in one

A good and safe feeling with one hand movement, simply get clean and well-groomed hands in passing.

- Hold dry hands approx. 5 cm below the dispenser and wait 2 seconds
- Thoroughly rub the dispensed ready-to-use gel for 30 seconds until completely wetted.

The hand gel thoroughly cleanses the hands and simultaneously supplies the skin with nourishing substances. It optimally protects them from drying out and provides a pleasant skin feeling. A sample tube (150ml) of our exclusive gel SanitCare Aloe is included.



Disinfection gel:

Unlike other disinfecting gels, Hand Cleansing Gel „SanitCare Aloe“ is enriched with qualitative carbomer (thickening agent in gels). This prevents a gummy and sticky consistency that could feel uncomfortable during use.



Virucidal and antibacterial:

The disinfection gel supplied with the product is effective against certain viruses (COVID-19) and bacteria. According to the CDC (Centers for Disease Control and Prevention), an alcohol content between 60-90% is effective against enveloped viruses, bacteria and fungi.

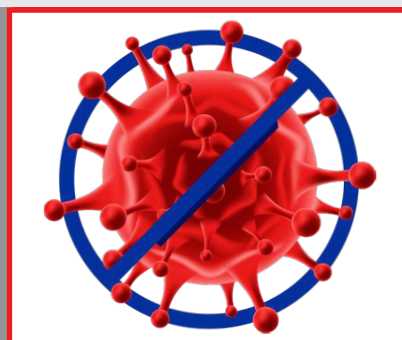

The stylish disinfection dispenser for all facilities.

Disinfectant dispenser DSH S champagne/black

„Addressing the senses“ - with the new disinfectant dispenser, a profane and perhaps even annoying process actually becomes a pleasant ritual. The DSH S is slim, stable, made of high-quality aluminium with a brushed look. The additional highlight is the ingenious 2-in-1 use. If the dispenser has to change its location and a floor-mounted unit can no longer be used, it can be converted into a tabletop unit in just a few easy steps.



Model: DSH S champagne/black
Item no.: 103075 | champagne
Item no.: 103082 | schwarz

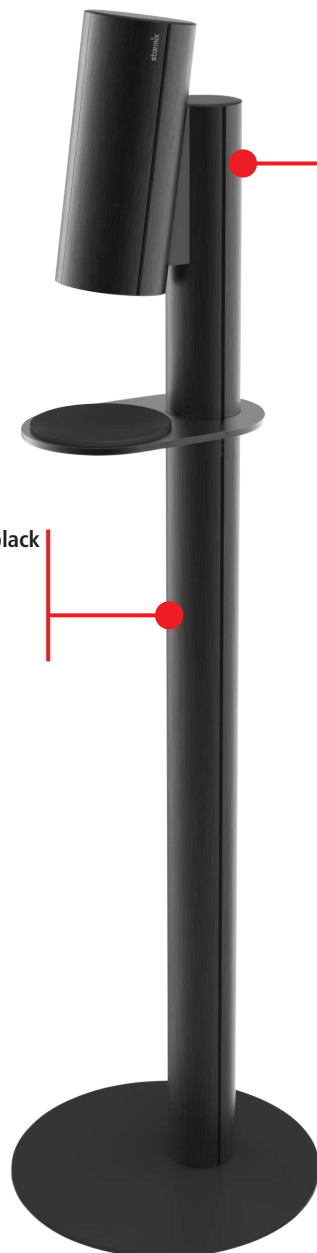

Equipment:

- Battery operated, up to 25.000 operations
- Contactless through automatic sensor control
- Refillable container for money disinfectant
- Container filling quantity 1.000 dispensing cycles
- 150 ml disinfection gel included
- Practical drip tray, easy to clean
- Available in champagne or black

Application areas:



Technical data:	
Power supply:	4 x AA 1,5 Volt
Voltage:	230-240 Volt~, 50/60 Hz
Volume Geltank:	1000 ml
Quantity / dispensing cycle:	1 ml
Dimensions standalone unit WxDxH (mm):	380 x 380 x 1410
Dimensions desktop unit WxDxH (mm):	175 x 285 x 463
Weight standalone unit:	9,5 kg
Weight desktop unit:	2,45 kg

Note:
The disinfectant dispenser can only be operated with disinfectant in gel form. We recommend starmix SanitCare Aloe gel, which has both disinfecting and caring properties.

Certification mark DSH S:



Hand hygiene and care in one with the hand cleansing gel.

Disinfection gel SanitCare Aloe 5L

This extraordinary virucidal and antibacterial disinfection gel was specially developed for the disinfection dispenser DSH S. It is the only one on the market that contains high-quality hyaluronic acid, whose caring and moisturizing effect is convincing all along the line. Once you have used it, you will not want to change.



Features:

- Disinfecting
- Caring ingredients like hyaluronic acid and vegetable glycerin
- Pleasant scent of aloe vera and green tea

Model: SanitCare Aloe 5L
Item no.: 103112

Technical data:	
Filling quantity:	5000 ml
Dimensions WxDxH (mm):	172 x 158 x 246
Weight:	4,6 kg

Registered according to EU law at the Croatian Ministry of Health under: HAND CLEANSING GEL | Registration number: Class: UPI-I-543-04/20-05/619 Number: 534-07-1/5-20-2

Ingredients:
alcohol denat, aqua, glycerin, carbomer, hyaluronic acid, phenoxyethanol, ethylhexylglycerin, triethanolamine, parfum, alpha-isomethyl ionone, butylphnyl methylpropional, citronellol, d-limonene, hexyl cinnamal, linalool.
Warning: For external use only. Highly flammable. Keep out of the reach of children. Avoid contact with eyes, mouth and mucous membranes. In case of contact, rinse immediately with plenty of water and seek medical advice.

The starmix stars.

Efficient, environmentally friendly, safe!

The starmix hot-air hand dryers are by far the most cost-efficient, modern and hygienic drying system around, while at same time being energy-saving and eco-friendly.

Durable, safe and maintenance-free – the ideal solution for your sanitary area.



COMPLETELY HYGIENIC!

Cleanliness and hygiene for your sanitary area! Thanks to their non-touch operation, starmix hair dryers are 100% hygienic and perform just as well as any other hand drying method. Independent studies have already proven this.

More on hygienic hand drying on [page 15](#) of this catalogue.



A COST-EFFECTIVE SYSTEM!

Up to 80 % cost savings compared to paper towels and cloth hand towel rolls. That means a saving of up to several thousand Euros a year (For more: scan the QR-Code or go to www.starmix.de).



ENVIRONMENTALLY FRIENDLY!

The Federal Agency for the Environment (UBA) confirms that hot air hand dryers are an ecologically better system for drying hands than recycled paper towels or cloth hand towel rolls.



ENVIRONMENTALLY FRIENDLY, RECYCLABLE!

All components can be 100 % recycled. Doesn't end up in a landfill, no waste incineration, no hazardous waste.



OFFICIALLY SANCTIONED!

According to the Workplace Guidelines set by the Federal Employment Ministry, the AirStar hot-air hand dryers are a fully-approved, hygienic system for hand drying.

IT'S WORTH IT!
THE STARMIX COST EFFICIENCY CALCULATOR



The efficiency calculator compares the drying methods of hand dryer, paper towel and textile towel with regard to various costs and taking into account the exact same prerequisites.

**CALCULATE NOW
AND REDUCE COSTS!**

Scan QR code or visit
www.starmix.de/en/calculator

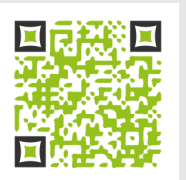

EXAMPLE:

At 200 uses per day on 365 days a year, the costs of using an XT 3001 compared to a paper towel dispenser can be reduced by:

1.433 EURO



The GreenStar – on behalf of the future.

Hygienic, ecological, sustainable!

Climate protection, compassionate action, careful handling of ourselves and the resources we have at our disposal - this concerns us all, this is what our GreenStar stands for!

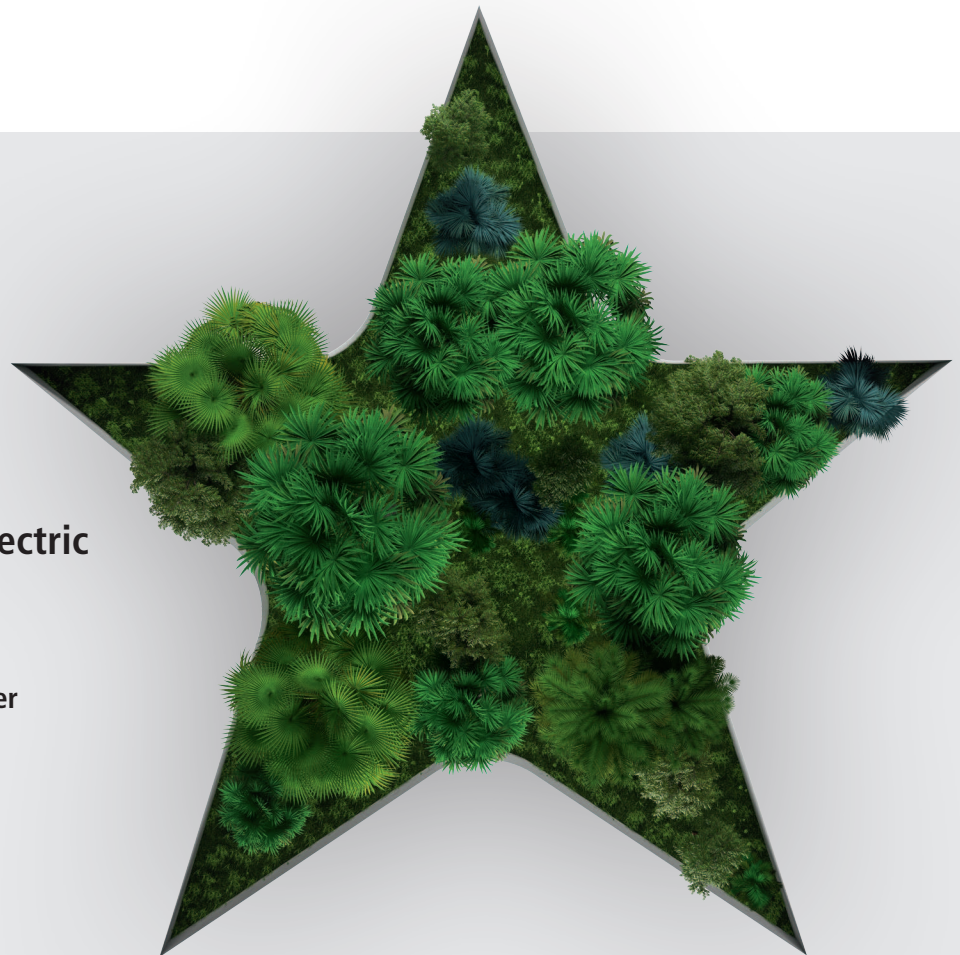

The GreenStar stands up!

8 good reasons to opt for electric hand dryers by starmix

- ★ The hygienic alternative to paper and fabric towels
- ★ Significantly lower costs
- ★ Energy efficient, making them environmentally friendly
- ★ No annoying paper waste
- ★ No need to store paper or fabric towels
- ★ No more empty towel dispensers
- ★ No unproductive personnel costs
- ★ Once assembled – can be used for years



Electric Handdryer
Association

WE ARE COMMITTED

Starmix is an initiator and founding member of the eHA (electric Handdryer Association) and therefore supports a sustainable and efficient market in the field of hand drying.



MORE INFORMATION

For more facts about hand dryers and hygiene, visit the eHA site
www.handdryerassociation.org



Water collector:

The **water collector** collects the water shaken from hands. The keeps the appliance and floor clean.



HEPA-panel filter:

Setting the standard in hygiene: with the HEPA-panel filter, which can be replaced without tools, and antibacterial, impact-resistant ABS plastic housing.

International **HACCP** certified.

Optional: ZeroSmell tab



Highspeed Hands-in hand dryer XT 3001.

The ultra fast hygienic dryer

The quickest and most energy efficient high speed hand dryer of its class. A strong, concentrated flow of air sweeps the water off both sides of the hands at a rapid 540 km/h. Hands are dry within approx. 10 seconds! At 30,000 rpm, the particularly durable brushless motor produces an effective high air speed. The clever double-filter system ensures utmost hygiene.

Plenty of space! Lots of space for the hands to dry without touching the device. Completely hygienic!



★ Ultra fast & hygienic

The infrared sensors activate the hand dryer without contact – simple and safe operation including for people with disabilities and children. The water from the hands is collected in a water collector that can be easily emptied and locked. Electronic sensors indicate when the water collector has to be emptied or the HEPA-filter has to be changed.

Convenient, safe and easy to operate:

1. Hold wet hands in the opening of the hand dryer from above.
2. The sensor automatically switches on the dryer until hands are removed.
3. If hands (or objects) are left in the appliance for too long, the dryer will switch off after 20 seconds.



electronic - no touch

MESH-filter:

For high-frequency sites or in contaminated room air.

An additional **MESH-filter** protects the HEPA-filter against coarse contamination. Simple to replace without the need for tools.



Motor reduction:

The power output can be reduced from 1,000 watts to 700 watts at the push of a button, lowering noise levels and energy consumption.



The ultra fast and clean hand dryer.

Highspeed Hands-in XT 3001



Features:

- Double filter system: HEPA- and MESH-filter
- Switch for reducing motor speed
- Brushless motor with approx. 3,000 hours of service life
- Water collector
- Non-touch on / off switch
- Antibacterial, impact-resistant ABS-plastic housing
- Electronic display for water collector and filter exchange
- Sensor safety shutdown
- Integrated assembly plate
- Electrical connection
- Optional: ZeroSmell tabs

Areas of application:



Sound pressure

Drying time

Model: XT 3001
Item no.: 016689 | white
 016672 | silver
 019062 | black



Certification mark for the XT 3001 series:



For about 1 million
ultra hygienic uses!



Technical data:

Net power:	max. 1,000 Watt	Air speed:	540 km/h
Voltage:	230-240 Volt~, 50/60 Hz	Sound pressure:	< 80 db(A)
Heat output:	without heater	Relative drying time:	approx. 10 seconds
Power output:	max. 1,000 Watt	Dimensions WxDxH (mm):	330 × 230 × 660
Revolutions per minute:	30,000 U/min	Weight:	9 kg

Guaranteed cleanliness for your sanitary area!

Hygienic AND ecological!

Hygienic hand drying – an issue that is often discussed and one about which many supposed experts like to share their opinion. BUT: It is worth taking a closer look. The fact is: Hot-air hand dryers are hygienic – that has been scientifically proven.

Compared to other hand drying methods, such as the paper or cotton hand towel, hand dryers are equal or superior, but in ecological terms, they are much better. Starmix hand dryers are the right choice if you are looking for an environmentally friendly and clean solution for your sanitary areas.



THE SOLUTION

AS AN EXAMPLE XT 3001

- Always available
- Lower energy consumption
- The most cost efficient and rapid system for drying hands
- Proven to reduce number of bacteria on washed hands*
- Best ecological footprint*



- Hygienic**
Proven in many independent studies*

- With HEPA-filter**
Removes 99.9% of all bacterial sized particles from the drying air



- Antibacterial, impact resistant housing**

- Global HACCP certified**
Approved for use in food processing plants



THE PROBLEM

AS AN EXAMPLE PAPER TOWELS

- High operation costs**
- Blocked toilets**
from improper disposal of paper towels
- Empty paper towel dispensers**
Hands cannot be dried or have to be wiped on trousers. Moist hands spread bacteria more than dry hands do!
- Expensive and frequent refilling, necessary to keep a stock**



- Produces a lot of waste, seldom recycled**
- Production is harmful to the environment**
- Poor ecological footprint**
Paper towels result in at least 70% higher carbon dioxide emissions than hot-air hand dryers*
- Overfilled waste paper baskets**

* All studies and sources connected to this information can be found at "starmix.de/en/hygiene"





No waste – no bacteria:

- No more annoying paper waste in sanitary facilities
- Up to **80 % cost savings** compared to paper towels and fabric towel roll
- **100 % recyclable**
- Drying air is warmed by waste heat from the motor



Energy saving at full power:

- Energy efficient: **Save electricity** even at high levels of use
- No false activation
- High speed hand drying in only **17 seconds** thanks to optimal air outlet profile and powerful blower



Highspeed Compact hand dryer T-C1. Powerful and economical

The Highspeed Compact-Class sets high standards: superior performance, advanced design, easy installation and comfortable operation. An appliance with a sensational price-performance ratio, for fast amortisation. The new generation of hand dryers with sophisticated starmix technology and the high level of quality „Made in Germany“.

Save money
with high speed.



Double safety system:



- No unnecessary use thanks to sensor-controlled safety switch off
- Protection against overheating with **temperature limiter**
- Flush-to-wall mounting/protected against misuse-safe assembly



Design meets comfort:

- Maintenance-free motor
- 1 x assembly = many years of use
- Cleanable air filters
- Impact resistant ABS plastic
- Integrated assembly plate
- High quality and easy-clean surface



The compact, reliable hand dryer in new, stylish design.

Highspeed Compact T-C1

With outstanding performance for fast, skin-friendly and hygienic hand drying. Considerable savings in energy costs: only 1,000 watt nominal power. Optimised air paths and air outlet nozzles as well as highly-developed technology ensure high-quality and high speed hand drying. Simple and easy to service assembly. The automatic sensor controlled safety switch-off and the maintenance-free motor ensure a long service life.



Features:

- Impact resistant ABS plastic housing
- Non-contact on/ off switch
- Sensor safety shutdown
- Mains plug
- Integrated assembly plate
- Safety temperature limiter
- Extractable air inlet screen
- Flush-to-wall mounting / protected against misuse



Areas of application:

Sound pressure

Drying time

Model: AirStar T-C1
Item no.: 017082 | white
 019604 black



Certification mark for T-C1:



The compact high speed-dryer with the best price-performance ratio!



Technical data:			
Net power:	max. 1,000 Watt	Air speed:	345 km/h
Voltage:	230-240 Volt~, 50/60 Hz	Sound pressure:	71 dB(A)
Heat output:	without heater	Relative drying time:	approx. 17 seconds
Power output:	max. 1,000 Watt	Dimensions WxDxH (mm):	268 x 182 x 304
Airflow:	38 l/s	Weight:	3 kg

Proper planning is essential for any architect, planner or operator.

Good planning is half the battle!

Public sanitary areas have developed a lot: They now need to be clean, functional and hard-wearing but at the same time aesthetically pleasing. A wellness oasis, in which one does not realise that it has been designed for functionality and safety. A challenge for any planner, architect and operator. With the starmix hand dryers, you will be able to meet all expectations – your heroes for the „sanitary area“.

Everything you need for your planning! Starmix hand dryers are certified and safe. You can find planning aids online at www.starmix.de/en/downloads

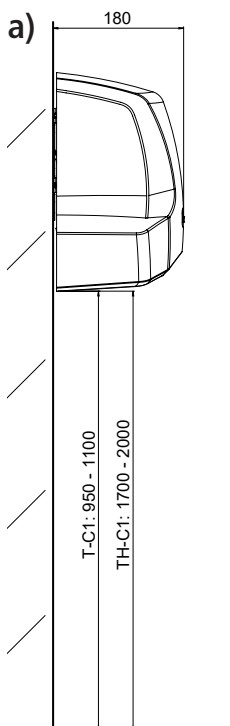

Planning assembly aid

Starmix helps you to plan your sanitary area – for a smooth and safe installation.

Installation aid T-C series

Starmix provides planning and installation guides to help with the safe assembly of hand dryers.

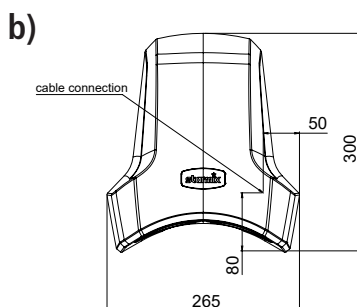

★ The environment is crucial!

All planners, architects and operators are faced with the same question: Which requirements need to be met? Starmix has the answers: Understatement is often what is required in more **sensitive areas**. For this purpose, starmix has developed a basic and comfort range of dryers as an ideal alternative. Quiet and cost-efficient. **Extra security?** You need a starmix vandal-proof dryer. They are mounted flush-to-wall and are thus protected against theft and misuse. **Hygiene regulations?** The XT 3001 is your starmix solution for certified, hygienic hand drying. For example in the food industry.

★ Efficiency and sustainability...

...in highly frequented sanitary areas is essential! Starmix highspeed-hand dryers are energy-efficient thanks to rapid hand drying. You can achieve **efficiency** and **environmental protection** by providing a method of hand drying that is paper-free. This means the planners and architects can fulfil their **responsibility** to the property developer and operator with regard to follow-on costs and **sustainability**. **You can find out more on the efficiency calculation on page 6 of the catalogue.**



Powerful and fast:

The ergonomically designed air nozzle and optimized air flow concentrates the air flow for effective high-speed hand drying in approx. 17 seconds.



Hard-wearing and safe:

- Flush-to-wall mounting to protect against misuse
- Stainless steel housing with 1.2 mm wall thickness
- Safety screws for theft-proof attachment



Vandal-proof hand dryers T-C1 M/Mw/XT 1000.

No chance –
these stars
are tough
guys

Strong, safe and efficient -
ideal for any public area!



In public spaces some equipment needs to be able to withstand the odd blow or kick. Thanks to high-quality components, the vandal-proof hand dryers can withstand the highest demands. The choice of white powder coated or matt brushed steel offers maximum security in public areas.

★ Vandal-proof and energy saving

The vandal-proof hand dryers for any facility that, above all, demands strong and hard-wearing appliances. Ideal for schools, sport facilities, discos or commercial establishments.

Choose to be on the safe side with starmix vandal-proof appliances:

- Vandal-proof steel housing
- Theft-proof attachment
- Flush-to-wall mounting to protect against misuse
- Maintenance-free and durable
- Quick and efficient hand drying
- Energy saving and cost-efficient

Compact and powerful:

- Extremely compact dimensions: smaller than an A4 envelope across
- High speed drying time of 17 seconds



The new vandal-proof power dryer for all types of facility.

Vandal-proof hand dryers T-C1 M & T-C1 Mw

For „hot temper“ this hand dryer will be a hard nut to crack. The sturdy housing is mounted directly to the wall for a completely secure attachment. The warm airflow helps to create a particularly pleasant hand drying process. The optimised, rotating air outlet nozzle concentrates the airflow for both effective and rapid hand drying.



Model: AirStar T-C1 Mw
Item no.: 017099 | Steel / white powder coated

Features:

- Mains plug
- Non-contact on / off switch
- High-quality stainless steel housing with 1.2 mm wall thickness
- Black nozzle insert
- Integrated assembly plate
- Electronic infrared proximity switch
- Sensor safety shutdown
- Thermal fuse safety

Areas of application:

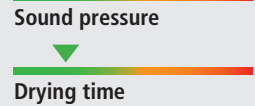

Model: AirStar T-C1 M
Item no.: 017105 | Steel / brushed matt

Features:

- Mains plug
- Non-contact on / off switch
- High-quality stainless steel housing with 1.2 mm wall thickness
- Black nozzle insert
- Integrated assembly plate
- Electronic infrared proximity switch
- Sensor safety shutdown
- Thermal fuse safety

Areas of application:

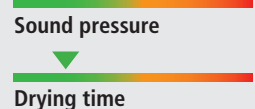

Technical data:			
Net power:	1,550 Watt	Air speed:	345 km/h
Voltage:	230-240 Volt~, 50/60 Hz	Sound pressure:	71 dB(A)
Heat output:	550 Watt	Relative drying time:	approx. 17 seconds
Power output:	1,000 Watt	Dimensions WxDxH (mm):	280 x 182 x 293
Airflow:	38 l/s	Weight:	4 kg



Certification mark T-C1 vandal proof series:



Unbelievably quick. Super-compact.

Vandal-proof hand dryers XT 1000 E & XT 1000 ES

The innovative, smallest high-speed hand dryer with outstanding features: Ultra fast - dries hands in just 17 seconds. The concentrated, high-speed airflow generated by the powerful high-performance blower quickly removes water drops and moisture from the skin surface. Ultra compact – significantly smaller than an A4 envelope crossways! A unique combination of high performance and micro format.



Model: XT 1000 E
Item no.: 012476 | Steel / white enamelled

Features:

- Electrical connection
- Non-contact on / off switch
- Electronic infrared proximity switch
- Sensor controlled safety switch-off after approx. 60 sec.
- Safety temperature limiter
- Thermal fusible cut-out
- High quality steel case with 1.2 mm wall thickness

Areas of application:

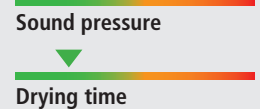

Model: XT 1000 ES
Item no.: 014302 | Steel / brushed matt

Features:

- Electrical connection
- Non-contact on / off switch
- Electronic infrared proximity switch
- Sensor controlled safety switch-off after approx. 60 sec.
- Safety temperature limiter
- Thermal fusible cut-out
- High quality steel case with 1.2 mm wall thickness

Areas of application:

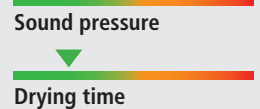

Technical data:			
Net power:	max. 1,000 Watt	Air speed:	324 km/h
Voltage:	230-240 Volt~, 50/60 Hz	Sound pressure:	75 dB(A)
Heat output:	500 Watt	Relative drying time:	approx. 17 seconds
Power output:	500 Watt	Dimensions WxDxH (mm):	250 x 140 x 180
Airflow:	28 l/s	Weight:	3.8 kg



Certification mark XT 1000 series:

IPX1 CE



The innovative assembly concept:

This mounting system allows simple, service-friendly wall mounting without opening the device.



Quick, clean, uncomplicated:

1. Install mains outlet socket (or permanent wiring)
2. Screw on assembly plate
3. Mount the ready-to-operate device
4. Plug in (or connect)
5. Screw on cover panel



The comfortable hand dryer. Durable, modern and quiet.

Comfort dryer TT 1800 E – for **ultra-quiet** use

The **maintenance-free** hand dryer in classic design impresses with strong, hygienic warm air flow for **particularly pleasant hand drying**. Simple, easy-to-service and economical wall mounting, without opening the device. The impact-resistant ABS housing and the maintenance-free, very quiet and above all long-lasting, brushless motor guarantee a long life. Sensor safety switch-off after approx. 4 minutes (e. g. in the case of chewing gum vandalism).



Features:

- Non-contact on / off switch
- Electronic infrared proximity switch
- With white light-emitting diode
- Brushless motor with > 4,000 h service life
- Sensor safety shutdown
- Safety mains plug connection
- Integrated assembly plate
- Safety temperature limiter
- Extractable air inlet screen
- Thermal fuse safety
- Flush-to-wall mounting / protected against misuse

Areas of application:



Model: TT 1800 E
Item no.: 195520 | white



Certification mark for TT 1800 E:



Technical data:			
Net power:	1,800 Watt	Air speed:	80 km/h
Voltage:	230-240 Volt~, 50/60 Hz	Sound pressure:	64 dB(A)
Heat output:	1,700 Watt	Relative drying time:	approx. 23 seconds
Power output:	100 Watt	Dimensions WxDxH (mm):	270 x 160 x 330
Airflow:	38 l/s	Weight:	3.5 kg





No waste – no bacteria:

Contactless activation for hygienic operation.

The smooth surface is also easy to clean, allowing no dirt to settle.



Space-saving:

With a depth of only 16.4 cm and a slight nozzle angle forward, comfortable hand drying is ensured and, at the same time, little space is required for the device.



The comfortable, low-cost hand dryer.

Basic dryer T 70 E – classic and hard-wearing

If you are looking for a compact and functional device which doesn't set you back too much, the T 70 E is the right choice. This hand dryer is very economical and reliable and fits into the smallest of spaces. The T 70 E is a good start in the world of high-quality starmix hand dryers.



Features:

- Non-contact on / off switch
- Electronic infrared proximity switch
- Sensor controlled safety switch-off after approx. 4 minutes
- Electrical connection
- Safety temperature limiter
- Extractable air inlet screen
- Thermal fuse safety

Areas of application:



Sound pressure

Drying time

Model: T 70 E
Item no.: 018492 | white



Certification mark for T 70 E:

IP23 EAC  

Technical data:			
Net power:	1,400 Watt	Air speed:	144 km/h
Voltage:	230-240 Volt~, 50/60 Hz	Sound pressure:	66 dB(A)
Heat output:	1,200 Watt	Relative drying time:	approx. 26 seconds
Power output:	200 Watt	Dimensions W×D×H (mm):	203 × 164 × 282
Airflow:	31 l/s	Weight:	2.3 kg



Starmix Hand dryers.

It's your choice!

Whether it is drying hands at high-speed or hard-wearing, sturdy appliances for your sanitary area – starmix offers the right hand dryer for every facility and every taste. For more information and assistance with your decision, please visit www.starmix.de



Model	XT 3001 white / XT 3001 silver / XT 3001 black	AirStar T-C1 white / T-C1 black	AirStar T-C1 Mw
Class	Highspeed Hands-in	Highspeed Compact	Vandal-proof dryer
Catalogue page	12/13 + 14	16/17 + 18	20/21 + 22
Item number	016689 / 016672 / 019062	017082 / 019604	017099
Features			
ON/OFF switch	touch-free	touch-free	touch-free
Housing material	ABS plastic, antibacterial	ABS plastic	Steel / 1.2 mm wall thickness
Case colour	white	white	white powder coated
Mains plug	no	yes	yes
sensor controlled safety switch-off	yes	yes	yes
Safety temperature limiter	no	yes	yes
Thermal fuse safety	no	no	yes
Integrated assembly plate	yes	yes	yes
Flush-to-wall mounting	no	yes	yes
Vandal-proof	no	no	yes
Technical data			
Total rated power (Watt)	max. 1,000	max. 1,000	1,550
Voltage	230 -240 Volt~, 50/60 Hz	230 -240 Volt~, 50/60 Hz	230 -240 Volt~, 50/60 Hz
Heat output (Watts)	without heater	without heater	550
Engine output (Watts)	max. 1,000	1,000	1,000
Engine speed (rpm)	30,000	–	–
Air speed (km/h)	540	345	345
Airflow (l/s)	–	38	38
Sound pressure level dB(A)	< 80	71	71
Relative drying time (seconds)	approx. 10	approx. 17	approx. 17
Run time (sec.) maximum	22	35	35
Protection type	IP33	IP23	IP23
Protection class	II	II	I
Weight (kg)	9	3	4
Dimensions WxDxH (mm)	330 × 230 × 660	268 × 182 × 304	280 × 182 × 293
Areas of use Applies to all:			



All planning and installation guides are available online at www.starmix.de/en/service



AirStar T-C1 M	XT 1000 E	XT 1000 ES	TT 1800 E	T 70 E
Vandal-proof dryer	Vandal-proof dryer	Vandal-proof dryer	Comfort dryer	Basic dryer
20/21 + 22	20/21 + 23	20/21 + 23	24/25	26/27
017105	012476	014302	195520	018492
touch-free	touch-free	touch-free	touch-free	touch-free
Steel / 1.2 mm wall thickness	Steel / 1.2 mm wall thickness	Steel / 1.2 mm wall thickness	ABS plastic	ABS plastic
brushed matt	white enamelled	brushed matt	white	white
yes	no	no	yes	no
yes	yes	yes	yes	yes
yes	yes	yes	yes	yes
yes	yes	yes	yes	yes
yes	no	no	yes	no
yes	yes	yes	yes	no
yes	yes	yes	no	no
1,550	1,000	1,000	1,800	1,400
230-240 Volt~, 50/60 Hz	230-240 Volt~, 50/60 Hz	230-240 Volt~, 50/60 Hz	230-240 Volt~, 50/60 Hz	230-240 Volt~, 50/60 Hz
550	500	500	1,700	1,200
1,000	500	500	100	200
–	–	–	–	–
345	324	324	80	144
38	28	28	38	31
71	75	75	64	66
approx. 17	approx. 17	approx. 17	approx. 23	approx. 26
35	60	60	240	240
IP23	IPX1	IPX1	IP23	IP23
I	I	I	II	II
4	3.8	3.8	3.5	2.3
280 × 182 × 293	250 × 140 × 180	250 × 140 × 180	270 × 160 × 330	203 × 164 × 282



Hairstyling with starmix:

The new AirStars make hair drying a pleasant experience. The nozzle makes hair styling easy. The height can be adjusted to a comfortable position for hair drying. The new design will complement the look of your sanitary area.



Hair-styling nozzle:

With a flexible 1.5 m hose for comfortable hair styling.

With an improved nozzle opening for concentrated airflow.



Highspeed Compact hair dryers TB-C1 and TH-C1.

Hair dryers – the AirStars

Achieving great results with hair drying! The starmix AirStar hair dryers turn hair drying into a pampering experience. Even more flexible, quicker and gentle on the hair. Whether in bathrooms, sports centres or hotels – the rotating nozzle, the flexible, long hose and the comfortable height adjustment let the AirStars shine wherever they are used!

Fully operational! The new AirStar hair dryers with highspeed-power.



★ The new generation

The new Highspeed Compact-Class is raising the bar: superior performance, modern design, simple assembly and comfortable operation. With the starmix quality standard “Made in Germany”. Experience the unbeatable performance for yourself.

Intelligent & safe:

- No unnecessary operation thanks to sensor controlled safety switch-off
- Safeguards against overheating with temperature limiter and protection of the heating elements
- Flush-to-wall mounting/protected against misuse

Energy saving at full power:

- Energy efficient: Save electricity even at high levels of use
- No false activation
- Air outlet and powerful blower

Easy to service:

- 1× assembly = many years of use
- Cleanable air inlet screen
- Impact resistant ABS plastic
- Integrated assembly plate
- High-quality, easy to clean surfaces

Height adjuster:

Hair drying at a comfortable height – individually adjustable to suit the user's height.



Nozzle outlet:

For quick hair drying and energy efficient use in an ergonomic design.



The popular hose appliance with a stylish design.
Highspeed Compact TB-C1

The AirStar Highspeed Compact-Class offers both comfortable hair drying and contemporary design. The integrated assembly plate facilitates uncomplicated installation of the appliance. The AirStar is particularly easy to keep clean thanks to the easily wipeable surface and cleanable air inlet screen. It ensures comfortable hair drying with the 1.5 m flexible hose with hair-styling nozzle.



Features:

- Impact resistant ABS plastic housing
- Automatic nozzle switch
- Sensor safety shutdown
- Mains plug
- Integrated assembly plate
- Safety temperature limiter
- Extractable air inlet screen
- Thermal fuse safety
- Flush-to-wall mounting / protected against misuse

Areas of application:



Model: AirStar TB-C1
Item no.: 017167 | white



Certification mark for TB-C1:



Technical data:			
Net power:	800 Watt	Air speed:	170 km/h
Voltage:	230-240 Volt~, 50/60 Hz	Sound pressure:	72 dB(A)
Heat output:	400 Watt	Run time:	240 seconds
Power output:	400 Watt	W×D×H (mm) incl. nozzle:	322 × 182 × 400
		W×D×H (mm) incl. hose:	322 × 182 × 500
Airflow:	18 l/s	Weight:	3.4 kg



Great combination.

Highspeed Compact TH-C1 & Height adjuster H-C1

The same applies here: Design meets comfort. Despite not having a hose, the AirStar TH-C1 guarantees gentle and effective hair drying thanks to its curved nozzle shape. The height adjustment H-C1 ensures that the AirStar can be brought to the optimum height with the help of the continuous adjuster.

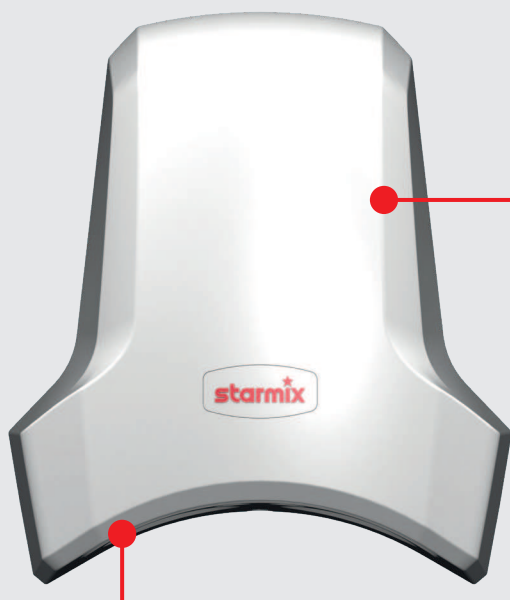

Features:

- Impact resistant ABS plastic housing
- Non-contact on / off switch
- sensor controlled safety switch-off
- Mains plug
- Integrated assembly plate
- Safety temperature limiter
- Thermal fuse safety
- Flush-to-wall mounting / protected against misuse
- Can be mounted on a height adjuster

Areas of application:



Model: AirStar TH-C1
Item no.: 017143 | white



Certification mark for TH-C1:



Height adjustment H-C1 (without TH-C1):

Hair drying at a comfortable height – individually adjustable. The ideal hair drying solution for children, the elderly and people with a disability in sports facilities, changing rooms, swimming pools or therapy centres.

Flat slide construction with weight compensation and integrated, concealed mains connection box. The hair dryer must be ordered separately. Adjustment range 55 cm, without intervals. Suitable for hair dryer TH-C1.

Model: AirStar H-C1
Item no.: 018447



Technical data TH-C1:			
Net power:	900 Watt	Air speed:	200 km/h
Voltage:	230-240 Volt~, 50/60 Hz	Sound pressure:	69 dB(A)
Heat output:	400 Watt	Run time:	240 seconds
Power output:	500 Watt	Dimensions WxDxH (mm):	268 x 182 x 304
Airflow:	22 l/s	Weight:	3 kg

Technical data H-C1:	
Adjustment range:	55 cm, without intervals
Dimensions WxDxH (mm):	215 x 57 x 1,040
Weight:	5 kg
Suitable for hair dryer TH-C1	



Nozzle:

Concentrates the airflow and ensures quick and pleasant hair drying which is gentle on the hair.



Sturdy, maintenance-free and durable – the starmix vandal-proof hair dryer.



The vandal-proof hair dryer for public facilities.

Vandal-proof hair dryer TH-C1 Mw & height adjuster H-C1 M – can withstand wear and tear of any area

The vandal-proof power hair dryer for sports facilities, public baths, schools, etc., with white enamelled steel housing and theft-proof attachment. All components are designed to withstand the most challenging conditions, sturdy, maintenance-free and durable. The nozzle concentrates the airflow, ensuring quick and pleasant drying which is gentle on the hair.



Features:

- Electrical connection
- Switch on/off with push button
- High quality stainless steel case with 2 mm wall thickness (vandal-proof)
- Flush-to-wall mounting / protected against misuse
- Thermal fuse safety
- Can be mounted onto a height adjuster
- Adjustable running time from 30 - 150 sec. (90 seconds factory setting)

Areas of application:



Model: AirStar TH-C1 Mw
Item no.: 019031 | Stainless steel / white powder coated



Certification mark for TH-C1 Mw:



Height adjuster H-C1 M (without TH-C1 Mw):

The new sturdy height adjuster for hair dryer TH-C1 Mw.

Features: Continuously adjustable with constant power rolling-band spring, guide rails made out of anodised special aluminium alloy. Concealed, vandal-proof cable guide, adjustment range 55 cm continuous.

Model: AirStar H-C1 M
Item no.: 020396



Technical data TH-C1 Mw:			
Net power:	900 Watt	Air speed:	200 km/h
Voltage:	230-240 Volt~, 50/60 Hz	Sound pressure:	71 dB(A)
Heat output:	400 Watt	Run time:	240 seconds
Power output:	500 Watt	Dimensions WxDxH (mm):	280 x 182 x 293
Airflow:	22 l/s	Weight:	4 kg

Technical data H-C1 M:	
Adjustment range:	55 cm, without intervals
Dimensions WxDxH (mm):	172 x 75 x 1,040
Weight:	8.4 kg
Suitable for hair dryer TH-C1 Mw	



Optimal heat distribution:

The nozzle ensures a uniform and powerful flow of air. Precise hair drying – quick and comfortable.



Easy to maintain:

- The operating time set by the factory can be adjusted by an engineer to between 30 - 480 seconds
- Automatic shutdown after approx. 4 minutes (e. g. in the case of chewing gum vandalism)



The compact hair dryer. Economical and reliable.

Basic hair dryer TH 70 Z – sturdy and inexpensive

Compact, economical and reliable hair dryer. The powerful airflow with optimal heat distribution allows for quick and comfortable hair drying. The particularly impact-resistant ABS housing guarantees a long service life. A cleanable lint filter prevents the motor and housing from getting clogged up. With automatic cut off.

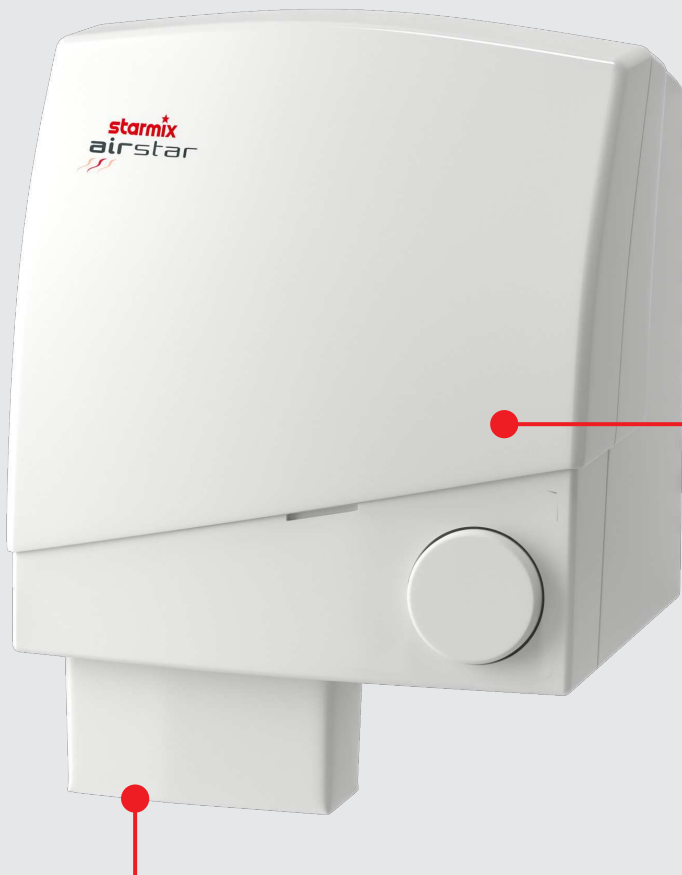

Features:

- Electrical connection
- Switch on/off with push button
- Impact resistant ABS plastic
- Safety temperature limiter
- Cleanable lint filter
- Thermal fuse safety
- Adjustable running time (default setting 4 minutes)

Areas of application:



Model: TH 70 Z
Item no.: 018508 | white



Certification mark for TH 70 Z:

IP23 EAC  

Technical data:			
Net power:	1,800 Watt	Air speed:	90 km/h
Voltage:	230-240 Volt~, 50/60 Hz	Sound pressure:	66 dB(A)
Heat output:	1,600 Watt	Run time:	240 seconds
Power output:	200 Watt	Dimensions W×D×H (mm):	203 × 164 × 282
Airflow:	31 l/s	Weight:	2.2 kg













Starmix hair dryers.

It's your choice!

Flexible styling, hair drying at a comfortable height - starmix hair dryers ensure pleasant hair drying.
Further information and decision aids can be found at www.starmix.de











Model	AirStar TB-C1	AirStar TH-C1	AirStar H-C1	
Class	Highspeed Compact	Highspeed Compact	Highspeed Compact height adjustment	
Catalogue page	32	33	33	
Item number	017167	017143	018447	
Features				
On / off switch	Nozzle switch, automatic	non-contact	–	
Housing material	ABS plastic	ABS plastic	–	
Case colour	white	white	–	
Permanent electrical wiring	no	no	yes	
Power plug	yes	yes	no	
Sensor controlled safety switch-off	yes	yes	–	
Safety temperature limiter	yes	yes	–	
Thermal fuse safety	yes	yes	–	
Integrated assembly plate	yes	yes	–	
Mounting on height adjuster	no	yes	–	
Flush-to-wall mounting	yes	yes	–	
Vandal-proof	no	no	–	
Flexible hose / hair-styling nozzle	yes	no	–	
Technical data				
Total rated power (Watt)	800	900	–	
Voltage	230 -240 Volt~, 50/60 Hz	230 -240 Volt~, 50/60 Hz	–	
Heat output (Watts)	400	400	–	
Engine output (Watts)	400	500	–	
Air speed (km/h)	170	200	–	
Airflow (l/s)	18	22	–	
Sound pressure level dB(A)	72	69	–	
Run time (auto. switch-off / sec.)	240	240	–	
Protection type	IP22	IP23	–	
Protection class	II	II	–	
Weight (kg)	3.4	3	5	
Dimensions WxDxH (mm)	322 × 182 × 400 incl. nozzle 322 × 182 × 500 incl. hose	268 × 182 × 304	215 × 57 × 1,040	
Areas of application	  	  	   	



All planning and installation guides are available online at www.starmix.de/en/service



	TH-C1 Mw	H-C1 M	TH 70 Z
	Vandal-proof dryer	Height adjustment vandal-proof dryer	Basic dryer
	34/35	34/35	36/37
	019031	020396	018508
	non-contact	–	Push-button
	Stainless steel/2 mm wall thickness	–	ABS plastic
	white powder coated	–	white
	no	yes	yes
	yes	no	no
	yes	–	no
	yes	–	yes
	yes	–	yes
	yes	yes	no
	yes	–	no
	yes	–	no
	yes	–	no
	no	–	no
	900	–	1,800
	230 -240 Volt~, 50/60 Hz	–	230 -240 Volt~, 50/60 Hz
	400	–	1,600
	500	–	200
	200	–	90
	22	–	31
	71	–	66
	240	–	240
	IP23	–	IP23
	I	–	II
	4	8.4	2.2
	280 × 182 × 293	172 × 75 × 1,040	203 × 164 × 282
	 	  	  

Hand-held hair dryers programme.

Comfortable hair drying and styling

Contemporary comfort in wellness and fitness areas, swimming pools and sauna facilities of ***hotel and guest bathrooms worldwide** – on land, at sea and in the air. Starmix hand-held hair dryers are **unobtrusive in every respect** – they benefit from a simple design including an elegant chrome look, are quiet and, thanks to their size, can be easily stored on the wall with a wall bracket, or just as easily in a drawer.

*Hair dryer for high frequented areas see p. 47.

The stars for the hotel business, spas, public baths and sports facilities.



Robust and comfortable:

- All hand-held hair dryers have an impact-resistant ABS-casing.
- Every device will be equipped with a hair-styling nozzle.
- Whether with a wall bracket or safety plug, every hand-held hair dryer is also equipped with a coiled cable, which can be stretched from 0.5 - 2.0 m, allowing plenty of space to move.



Safety features of the starmix hand-held hair dryers:

- All hand-held hair dryers have of course been tested and certified.
- An explanation and description of every certification mark can be found on page 51 of this catalogue.

Certification mark for the HF hotel special series:



Certification mark for the HF and TF series:



Certification mark for the TFC 18:



starmix hand-held hair dryer HFS 18

Features:

- Power plug
- 3 settings: – 1.875 W max.
- 2 air speeds
- Separate cool button
- Extra long coiled cable, 250 cm extendable
- Filter cover removable
- Softtouch surface

Technical data:

Rated power: 1.875 Watts
Voltage: 220-240 Volt~, 50/60 Hz

Dimensions and weight:

- W 230 mm, D 85 mm, H 280 mm
- Weight 0,615 kg

Item no.: 019239 | black

**1875 Watts!
Softtouch surface**



starmix hand-held hair dryer HFF 16

Features:

- Power plug
- 2 settings: – 1.600 W max.
- 2 air speeds
- Separate cool button
- Filter cover removable
- Foldable handle
- Softtouch surface

Technical data:

Rated power: 1.600 Watt
Voltage: 220-240 Volt~, 50/60 Hz

Dimensions and weight:

- W 140 mm, D 77 mm, H 231 mm
- W 200 mm, D 77 mm, H 120 mm folded
- Weight 0,390 kg

Item no.: 019246 | black

**Foldable handle !
Softtouch surface**



starmix hand-held hair dryer TFC 12 / TFC 16 / TFC 18

Features:

- Power plug
- Safety temperature limiter
- 4 settings: 0 – Cool – 600 W – 1,200 W
- 2 air speeds

Technical datas:

Rated power TFC 12: 1,200 Watt
 Rated power TFC 16: 1,600 Watt
 Rated power TFC 18: 1,800 Watt
 Voltage: 230-240 Volt~, 50/60 Hz

Dimensions and weight:

W 177 mm, D 86 mm
 Weight approx. 0.5 kg

Item no. TFC 12: 038926 | black/chrome

Item no. TFC 16: 020723 | black/chrome
 Item no. TFC 16: 157221 | white/chrome

Item no. TFC 18: 014944 | black/chrome

1800 Watts !

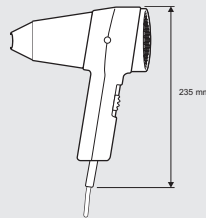
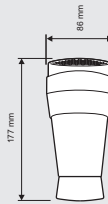

starmix hand-held hair dryer TFCT 16

Features:

- Power plug
- Safety temperature limiter
- 3 settings: Cool – 800 W – 1,600 W
- Separate safe on/off push button
- 2 air speeds

Technical data:

Rated power: 1,600 Watt
 Voltage: 230-240 Volt~, 50/60 Hz

Dimensions and weight:

- W 177 mm, D 86 mm, H 235 mm
- Weight 0.5kg

Item no.: 198125 | black/chrome

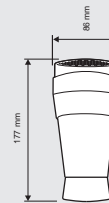
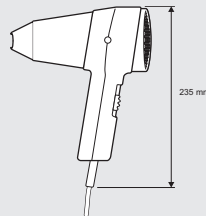

starmix hand-held hair dryer TFCW 16

Features:

- Permanent electrical wiring: Safety wall bracket with nightlight and power cut-off switch
- Safety temperature limiter
- 4 settings: 0 – Cool – 800 W – 1,600 W
- 2 air speeds

Technical data:

Rated power: 1,600 Watt
 Voltage: 230-240 Volt~, 50/60 Hz

Dimensions and weight:

W 235 mm, D 125 mm, H 200 mm incl. wall bracket
 weight approx. 0.8 kg incl. wall bracket

Item no.: 013039 | black

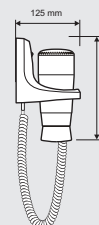
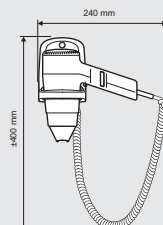

starmix hand-held hair dryer HFTW 12 S

Features:

- Permanent electrical wiring: Safety wall bracket with nightlight and power cut-off switch, with shockproof socket for electrical devices (230 V)
- Safety temperature limiter
- 3 settings: Cool – 600 W – 1,200 W
- Separate safe on/off push button
- 2 air speeds

Technical data:

Rated power: 1,200 Watt
Voltage: 230-240 Volt~, 50/60 Hz

Dimensions and weight:

- W 245 mm, D 150 mm, H 245 mm incl. wall bracket
- Weight 0.7 kg incl. wall bracket
- Inside diameter of wall bracket approx. 70 mm

Item no.: 012957 | white

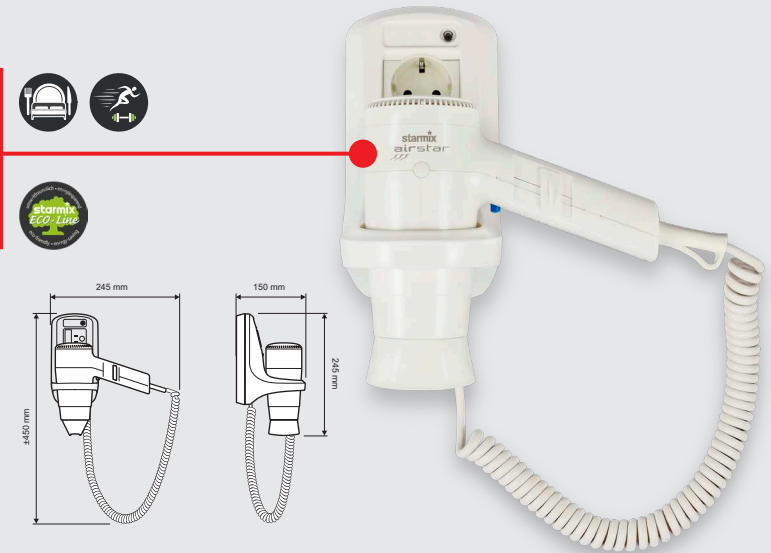

starmix hand-held hair dryer HFTW 12 R

Features:

- Permanent electrical wiring: Safety wall bracket with nightlight and Power cut-off switch with switchable dry shaver socket (115 V/230 V)
- Safety temperature limiter
- 3 settings: Cool – 600 W – 1,200 W
- Separate safe on/off push button
- 2 air speeds

Technical data:

Rated power: 1,200 Watt
Voltage: 230-240 Volt~, 50/60 Hz

Dimensions and weight:

- W 245 mm, D 150 mm, H 245 mm incl. wall bracket
- Weight 1.25 kg incl. wall bracket
- Inside diameter of wall bracket approx. 70 mm

Item no.: 012940 | white

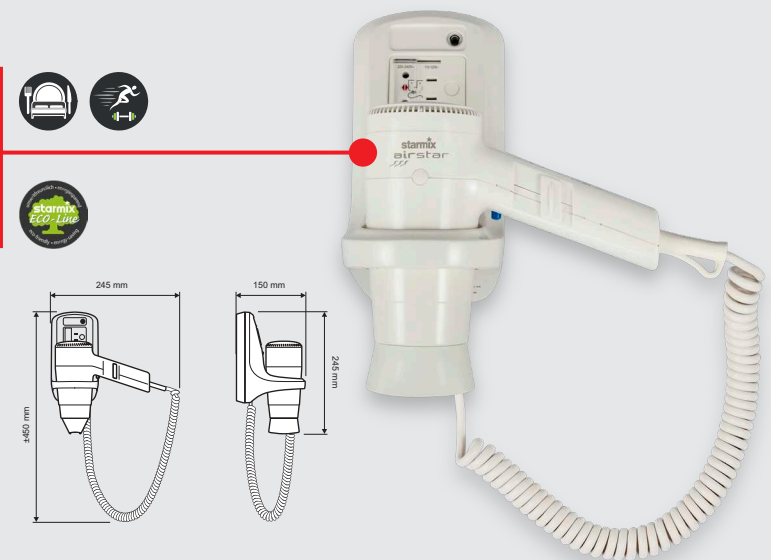

starmix hand-held hair dryer HFTW 16

Features:

- Permanent electrical wiring: Safety wall bracket with nightlight and power cut-off switch
- Safety temperature limiter
- 3 settings: Cool – 800 W – 1,600 W
- Separate safe on/off push button
- 2 air speeds

Technical data:

Rated power: 1,600 Watt
Voltage: 230-240 Volt~, 50/60 Hz

Dimensions and weight:

- W 240 mm, D 125 mm, H 200 mm incl. wall bracket
- weight approx. 0.78 kg incl. wall bracket
- Inside diameter of wall bracket approx. 70 mm

Item no.: 012964 | black

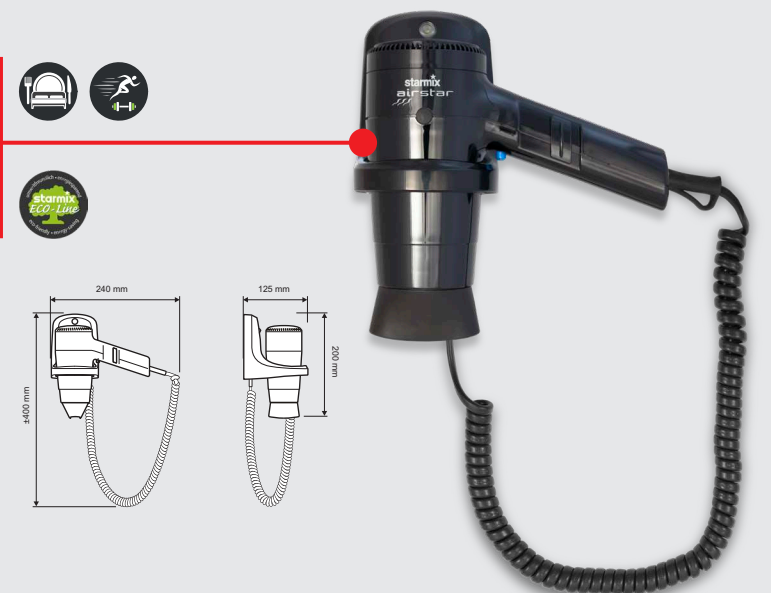

starmix hand-held hair dryer HFW 12

Features:

- Permanent electrical wiring: Safety wall bracket with night light and power cut-off switch
- Safety temperature limiter
- 4 settings: 0 – Cool – 600 W – 1,200W
- 2 air speeds

Technical data:

Rated power: 1,200 Watt
Voltage: 230-240 Volt~, 50/60 Hz

Dimensions and weight:

- W 235 mm, D 125 mm, H 200 mm incl. wall bracket
- Weight 0.78 kg incl. wall bracket
- Inside diameter of wall bracket approx. 70 mm

Item no.: 012995 | white

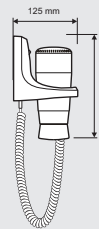
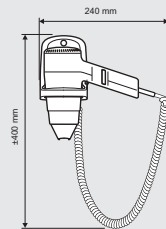

starmix hand-held hair dryer HF 12

Features and technical data:

like HFW 12, without wall bracket, with power plug

Dimensions and weight:

- W 177 mm, D 86 mm, H 235 mm
- Weight 0.46 kg

Item no.: 013022 | white

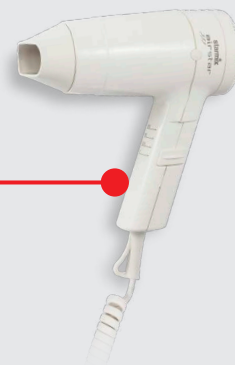

starmix hand-held hair dryer HFTW 12

Features:

- Permanent electrical wiring: Safety wall bracket with night light and power cut-off switch
- Safety temperature limiter
- 3 settings: Cool – 600 W – 1,200 W
- Separate safe on/off push button
- 2 air speeds

Technical data:

Rated power: 1,200 Watt
Voltage: 230-240 Volt~, 50/60 Hz

Dimensions and weight:

- W 240 mm, D 125 mm, H 200 mm incl. wall bracket
- Weight 0.78 kg incl. wall bracket
- Inside diameter of wall bracket approx. 70 mm

Item no.: 012933 | white

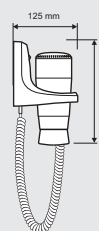
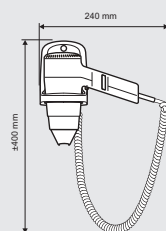

starmix hand-held hair dryer HFT 12

Features and technical data:

like HFTW 12, without wall bracket, with power plug

Dimensions and weight:

- W 177 mm, D 86 mm, H 235 mm
- Weight 0.48 kg

Item no.: 012988 | white



starmix hand-held hair dryer HFSW 12

Features:

- Permanent electrical wiring: Safety wall bracket with night light and power cut-off switch
- Safety temperature limiter
- With safety on/off push button = 1 setting (1,200 W) and 1 air speed

Technical data:

Rated power: 1,200 Watt
Voltage: 230-240 Volt~, 50/60 Hz

Dimensions and weight:

- W 240 mm, D 125 mm, H 200 mm incl. wall bracket
- Weight 0.78 kg incl. wall bracket
- Inside diameter of wall bracket approx. 70 mm

Item no.: 012889 | white

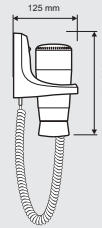
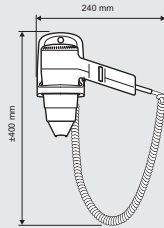

starmix hand-held hair dryer HFS 12

Features and technical data:

like HFSW 12, without wall bracket, with power plug

Dimensions and weight:

- W 177 mm, D 86 mm, H 235 mm
- Weight 0.48 kg

Item no.: 012926 | white



Specialised hand-held hair dryers.

For more demanding areas

The specialised models to cope with intense use in wellness areas, public swimming baths and sports facilities. These hand-held hair dryers benefit from a contemporary design and perfectly complement the overall look of the sanitary area. The hair dryer's impact resistant casing means it is also perfect for campsites.

Extremely durable and impact resistant. Safety in the sanitary area.



starmix hand-held hair dryer HFXW 20

AC Long-life collector motor

Features:

- Power plug
- Separate wall bracket
- Safety temperature limiter
- Safety push button
- 6 temperatur/airflow setting combinations

Technical data:

Rated power: 1,700 – 2,000 Watt
Voltage: 230-240 Volt~, 50/60 Hz

Dimensions and weight:

- W 255 mm, D 89 mm, H 285 mm
- Weight 0.78 kg incl. wall bracket + 2 nozzles

Item no.: 020501 | black



Certification marks for HFXW 20:

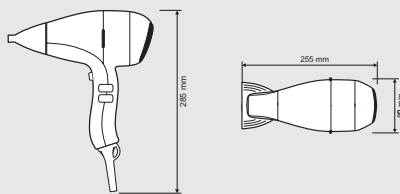

Wall bracket HFXW 20

The safe and sturdy HFXW 20

With a cored wire heating element "SECURITY" and AC long-life collector motor (more than 2,000 h lifetime) for maximum durability, quality and safety.

The detachable metal filter makes it possible to safely and easily remove any lint that has accumulated.



Nozzle for HFXW 20:

In addition to the separate wall bracket, the HFXW 20 also includes an extra-narrow styling nozzle (6.5 cm) and an extra thinner nozzle.



Installation or operation of starmix hair dryers.

Planning guides

Starmix provides planning and installation guides for all appliances fitted in the construction or refurbishment of changing rooms, bathrooms and public facilities. We would also be happy to offer you individual advice on safety and the assembly of starmix appliances in sanitary areas.



Everything you need for planning. For all planning and installation guides, scan the QR code or visit www.starmix.de/en/downloads

H-C1

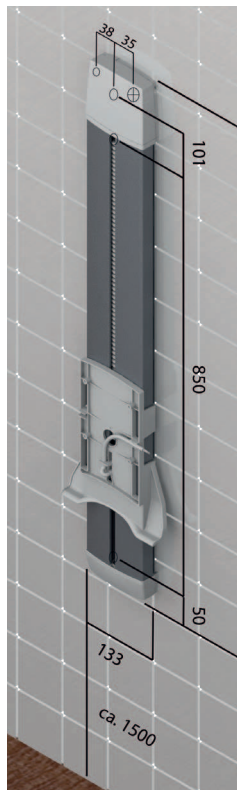

Hair dryer

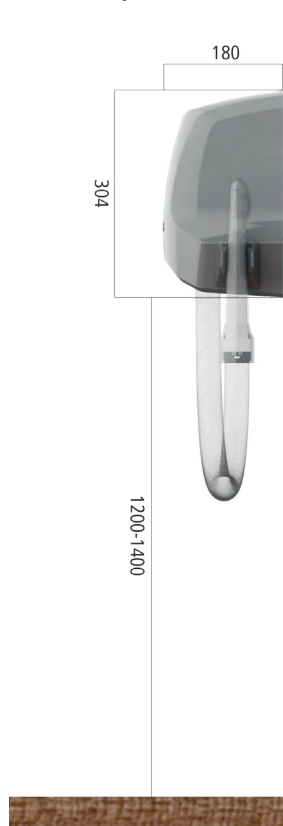

★ Installation & Safety

- The installation must be carried out according to the VDE regulation VDE 0100, section 701. Furthermore, the installation regulations and technical connection conditions of the PSCs need to be adhered to, which supplement the VDE-regulations.
- VDE 0107 also applies to medically used bathing areas.

Safety distances

Protective measures include for example:

- Compliance with protection areas 0.6m around showers and bath tubs and 1.2 m around shower heads.
- Sockets and switches are allowed within these distances if they are protected by a residual-current device 30 mA.

Adhering to protection class I with a protective earth connection is not intended for domestic use in the case of hair dryers, but exclusively for use in commercial premises.

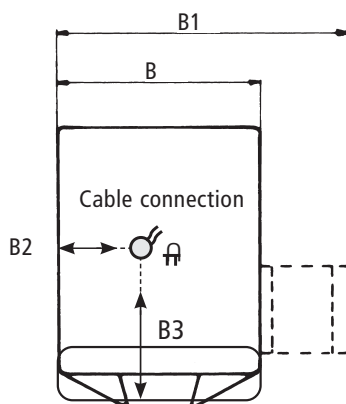

Safety distances. Please see text above.

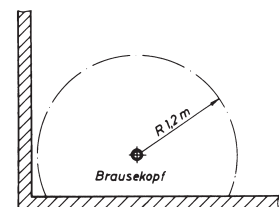
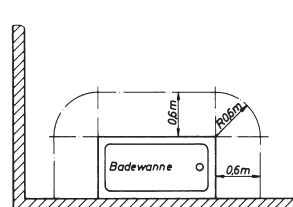
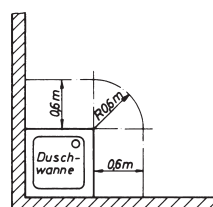









Starmix hand-held hair dryers.

It's your choice!

Fully customised – with or without plug? You decide which hand-held hair dryer will turn your bathroom into a hairstyling paradise. Further information and decision aids can be found at www.starmix.de



Model	HFS 18	HFF 16 (foldable)	TFC 12	TFC 16	TFC 18	TFCT 16	TFCW 16	HFTW 12 S	
Catalogue page	41	41	42	42	42	42	42	43	
Item number	019239	019246	038926	020723 bl 157221 wh	014944	198125	013039	012957	
Features									
Rated power (Watt)	1,875	1,600	1,200	1,600	1,800	1,600	1,600	1,200	
Power setting	3	3	4	4	4	3	4	3	
Air speeds	2	2	2	2	2	2	2	2	
Safety push button on / off	no	no	no	no	no	yes	no	yes	
Hair-styling nozzle	yes	yes	yes	yes	yes	yes	yes	yes	
Safety temperature limiter	yes	yes	yes	yes	yes	yes	yes	yes	
Wall bracket / electric permanent electrical wiring	no	no	no	no	no	no	yes	yes	
Power plug	yes	yes	yes	yes	yes	yes	no	no	
Nightlight on wall bracket	no	no	no	no	no	no	yes	yes	
Power cut-off switch	no	no	no	no	no	no	yes	yes	
Coiled cable (m)	0.5 - 2.5	0.5 - 2	0.5 - 2	0.5 - 2	0.5 - 2	0.5 - 2	0.5 - 2	0.5 - 2	
Reversible dry shaver socket 115/230 V~ (EU- + US-socket)	no	no	no	no	no	no	no	no	
Power plug on wall bracket	no	no	no	no	no	no	no	yes	
Wall bracket WH and WHS	optional	optional	optional	optional	optional	optional			
Areas of application									



HFTW 12 R	HFTW 16	HFW 12	HF 12	HFTW 12	HFT 12	HFSW 12	HFS 12	HFXW 20
43	43	44	44	44	44	45	45	46 + 47
012940	012964	012995	013022	012933	012988	012889	012926	020501
1,200	1,600	1,200	1,200	1,200	1,200	1,200	1,200	1,700 – 2,000
3	3	4	4	3	3	1	1	3
2	2	2	2	2	2	1	1	2
yes	yes	no	no	yes	yes	yes	yes	yes
yes	yes	yes	yes	yes	yes	yes	yes	yes
yes	yes	yes	yes	yes	yes	yes	yes	yes
yes	yes	yes	no	yes	no	yes	no	yes / no
no	no	no	yes	no	yes	no	yes	yes
yes	yes	yes	no	yes	no	yes	no	no
yes	yes	yes	no	yes	no	yes	no	no
0.5 - 2	0.5 - 2	0.5 - 2	0.5 - 2	0.5 - 2	0.5 - 2	0.5 - 2	0.5 - 2	0.6 - 1.8
yes	no	no	no	no	no	no	no	no
no	no	no	no	no	no	no	no	no
			optional		optional		optional	

Perfect for your guest bathroom.

Appliances by starmix

A clean and comfortable bathroom is an absolute must – the starmix accessories will help you protect your appliances and keep the place looking tidy. With the wall brackets, the starmix hand-held hair dryers are always ready to hand. The storage bags protect the casing from scratches.

starmix velvet bag

Storage bag for hand-held hair dryers

Features:

- With embroidery
- For safe and clean storage of starmix Hand-held hair dryers with power plug

Dimensions and weight:

- W 253 mm, H 410 mm
- Weight 0.066 kg

Item no.: 705163 | black



starmix chrome wall bracket WHC

Features:

- Strong, high quality chrome
- Inside with plastic rint to protect the handheld hair dryers.

Dimensions and weight:

- w 79 mm, D 100 mm, H 54 mm
- Weight 0,18 kg
- Inner diameter approx. 70 mm

Item no.: 158105 | chrome

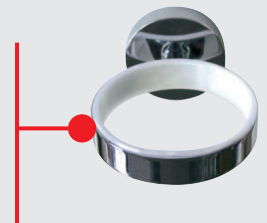

starmix wall bracket WH

Features:

- Safety wall bracket for permanent electrical wiring with Safety power cut-off switch and sensor controlled night light
- Perfectly fits models TFC... and HF...
- Also suitable for retrofitting

Dimensions and weight:

- W 89 mm, D 122 mm, H 122 mm
- Weight 0.12 kg
- Inside diameter approx. 60 mm

Item no.: 013053 | white
013046 | black



starmix wall bracket WHS

Features:

- Smooth lining to protect the hand-held hair dryer
- Anti-theft cable tracks
- Perfectly fits models TFC and HF...

Dimensions and weight:

- W 74 mm, D 93 mm, H 50 mm
- Weight 0.18 kg
- Inside diameter approx. 70 mm

Item no.: 019253 | chrome
019260 | black



Shower and tub handle program.

Safe comfort in the bathroom

From the basic to the premium version - the grab bars from starmix are all characterized by high quality standards and high-quality design.

Safety first -
Grab bars



Strong and durable:

The handles from the starmix range are designed for a load capacity of up to 110 kg.



Safety of the starmix Bathroom-program:

- All grab bars are comprehensively tested and certified.
- The explanation and description of all test marks can be found on page 58.

Certification marks for grab bars:



Bauart geprüft
Sicherheit
Regelmäßige
Produktions-
überwachung
www.tuv.com
ID: 111321195

Certification marks for shower seat:



starmix bath/shower grab bar WGP AE 30 / WGP AE 45 / WGP AE 60**Finish: Premium, aluminium anodized**

- integrated anti-slip protection made of TPE
- individually shortenable in length
- Certified safety up to 110 kg

Dimensions and weight:

- L 300 mm, W 76 mm, H 74 mm / weight 0.474 kg
- L 450 mm, W 76 mm, H 74 mm / weight 0.685 kg
- L 600 mm, W 76 mm, H 74 mm / weight 0.800 kg

Item no.: 019475 | 30 cm

Item no.: 019482 | 45 cm

Item no.: 019499 | 60 cm

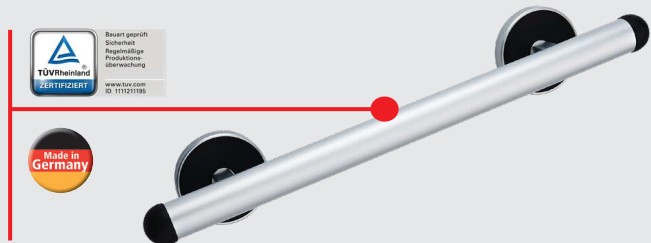
**starmix bath/shower grab bar WG EH 30 / WG EH 45****Finish: stainless steel, high-gloss polished**

- Certified safety up to 110 kg

Dimensions and weight:

- L 380 mm, W 80 mm, H 90 mm / weight 0.535 kg
- L 530 mm, W 80 mm, H 90 mm / weight 0.684 kg

Item no.: 019369 | 30 cm

Item no.: 019376 | 45 cm

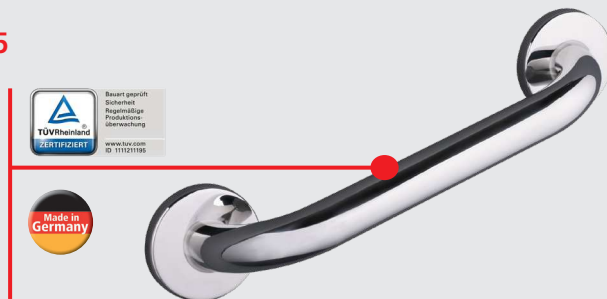
**starmix bath/shower grab bar WG EM 30 / WG EM 45****Finish: stainless steel, matte**

- Certified safety up to 110 kg

Dimensions and weight:

- L 380 mm, W 80 mm, H 90 mm / weight 0.535 kg
- L 530 mm, W 80 mm, H 90 mm / weight 0.684 kg

Item no.: 019383 | 30 cm

Item no.: 019390 | 45 cm

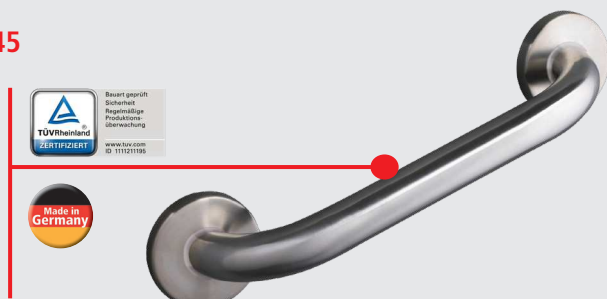
**starmix bath/shower grab bar WG EP 30 / WG EP 45****Finish: stainless steel, polished, with non-slip grip surface**

- Certified safety up to 110 kg

Dimensions and weight:

- L 380 mm, W 80 mm, H 90 mm / weight 0.535 kg
- L 530 mm, W 80 mm, H 90 mm / weight 0.684 kg

Item no.: 019420 | 30 cm

Item no.: 019437 | 45 cm



starmix bath/shower grab bar WG AW 30 / WG AW 45

Finish: aluminium, white coated

- Certified safety up to 110 kg

Dimensions and weight:

- L 380 mm, W 80 mm, H 90 mm / weight 0.494 kg
- L 530 mm, W 80 mm, H 90 mm / weight 0.576 kg

Item no.: 019406 | 30 cm

Item no.: 019413 | 45 cm



starmix angled grab bar WHG EP

Finish: stainless steel, high polished

- Certified safety up to 110 kg

Dimensions and weight:

- L 530 mm, W 220 mm, H 120 mm
- Weight 0.662 kg

Item no.: 019444 | stainless steel



starmix Fix & Clean

Finish: Adhesive for mounting handles without separate tools

- Residue-free demounting
- Certified safety up to 100 kg

Item no.: 019505



starmix shower seat DKS AS

Finish: Premium, aluminium black

- Certified safety up to 150 kg

Dimensions and weight:

- Ø 355 mm
- Weight 3.318 kg

Item no.: 019468

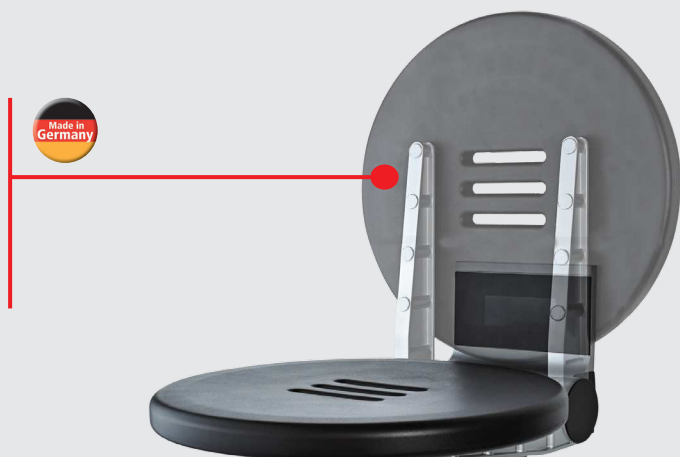

All grab bars and shower seat

Products for the guest room.

The finishing touch

The provision of kettles and ironing facilities in guest rooms ensures ultimate comfort and convenience. The starmix range includes a small but perfectly formed selection of premium products.

High-quality equipment
in the hospitality, that
everyone can afford.



High quality and modular

All kettles are brushed stainless steel. The cable can be neatly coiled within the 360°-base, which is included in the box. This and the serving tray make for a modern pairing.



Various options in one unit

All products from the "Ironing" range can be combined to create a perfect unit.



starmix water kettle WK 0.5

Features:

- 500 ml filling volume
- Water level gauge window
- Concealed heating element for easy cleaning
- Cordless water kettle
- 360° base with integrated cord tidy
- Automatic steam and power shutdown
- Hinged trigger style locking lid

Technical data:

Rated power: 800-950 Watt
Voltage: 220-240 Volt, 50/60 Hz

Dimensions and weight:

- W 190 mm, H 185 mm, Ø lid 90 mm, Ø base 143 mm
- Weight 0,75 kg

Item no.: 019284 | stainless steel brushed

Certification mark WK 0.5:

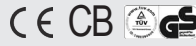

starmix water kettle WK 1.0

Features:

- 1000 ml filling volume
- Water level gauge window
- Concealed heating element for easy cleaning
- Cordless water kettle
- 360° base with integrated cord tidy
- Automatic steam and power shutdown
- Hinged trigger style locking lid

Technical data:

Rated power: 800-950 Watt
Voltage: 220-240 Volt, 50/60 Hz

Dimensions and weight:

- W 207 mm, H 197 mm, Ø lid 95 mm, Ø base 143 mm
- Weight 0,86 kg

Item no.: 019291 | stainless steel brushed

Certification mark WK 1.0:



starmix tray T 1

Features:

- First grade bamboo material - environmentally friendly (renewable resource, subject to color and grain variations)
- Cable routing for water kettle base, prevents theft
- Food grade safety
- Space saving modular design
- Curved contour edges, easy to clean
- Suitable for water kettle with base diameter 143 mm, see WK 0.5 und WK 1.0

Dimensions and weight:

- L 260 mm, W 260 mm, H 30 mm
- Weight 0,725 kg

Item no.: 019277 | black





Iron center: perfectly matched products
for a complete unit.



starmix ironing board BB 1

Features:

- Robust tube frame legs and sub frame
- Board: steam flow metal mesh
- 2mm foam & 5 mm felt combination padding
- Cover material in charcoal grey, heat reflective
- Smooth binding edges to withstand fraying
- Strong height adjustment rail and double handle

Dimensions and weight:

- Full size: Board L 1090 mm, W 380 mm, H 870 mm
- Compact size: L 1330 mm, W 380 mm, H 70 mm
- Weight 4.68 kg

Item no.: 019307 | chrome-plated brass

Replacement covers available!



starmix steam iron DB 1

Features:

- Safety shutdown - 30 sec. on the sole, 5 min. upright
- Anti-drip, to prevent water dripping through steam outlets
- Anti-calc to remove the limescale build up
- Thermostat, silver coated for much more accurate thermostat temperature dial match
- 250 ml water tank
- Extra long cable cord, 250 cm
- Non-stick soleplate
- LED green & red in-use indicator light
- Auto-Off indicator light

Technical data:

Rated power: 1600 Watts
Voltage: 220-240 Volt, 50/60 Hz

Dimensions and weight:

- Sole: L 206 mm, B 113 mm
- Weight 0.982 kg

Item no.: 019352 | black/grey

Certification mark DB1:



starmix Set Iron/Ironing board holder BBH 1

Finish: Metall

For theft-proof fixation of the iron DB 1 to the ironing board BB1. Storing of the ironing board with the holder to the wall. Suitable with BBA P and BBA S.

Dimensions and weight:

- H 356 mm, W 135 mm, D 130 mm
- Weight 1.055 kg

Item no.: 019314 | silver

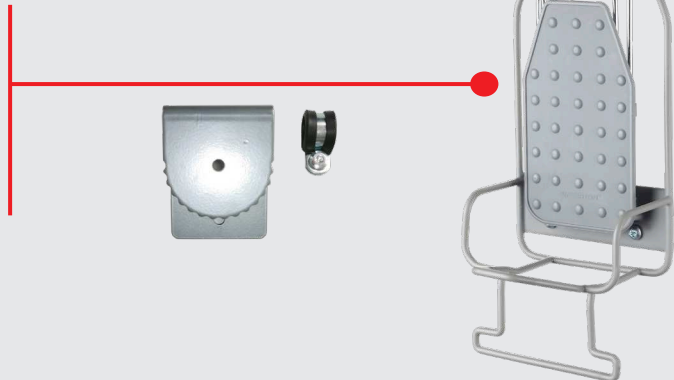

starmix ironing board hook BBA P

Finish: plastic

For storing ironing boards with the hook e.g. on clothes rails. No tools needed.

Dimensions and weight:

- H 126 mm, W 65 mm, D 62 mm
- Weight 0,096 kg

Item no.: 019345 | silvergrey

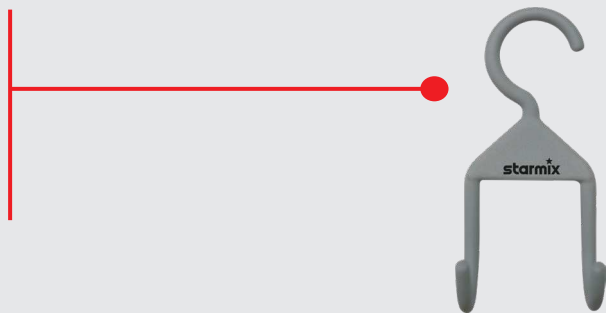

starmix ironing board hook BBA S

Finish: steel

For storing ironing boards. Wall mounted with screws.

Dimensions and weight:

- H 203 mm, W 105 mm, D 65 mm
- Weight 0,145 kg

Item no.: 019338 | silver/grey

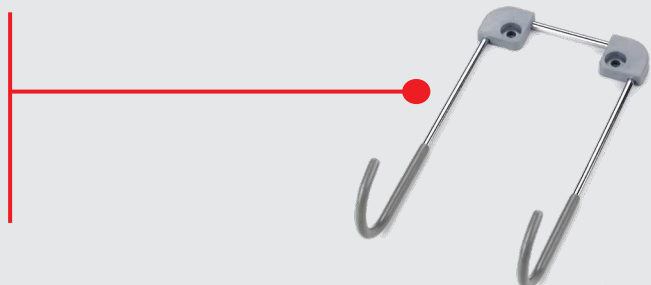

Quiet, compact, powerful.

Dry vacuum cleaner TS 714

The optimal vacuum cleaner for dry cleaning in hotels, restaurants and offices. With the additional HEPA filter a plus for the cleaning, especially for people who are allergic to house dust.

Full power and
low noise.



Comfortable work

Large on/off switch, parking position and insertion for accessories. Comfortable one-handed transport. With extra long wheelbase for optimal safety against overturning.



Quiet and safe all round

TS 714 with super quiet noise-dampened motor, elastic bumpers and rubber rollers for quiet easy rolling. Bottom runner to help it roll off door sills almost barrier-free.



Areas of application:



starmix TS 714 RTS HEPA

Features:

- Eco mode
- Noise insulated
- Main filter: fleece filter basket
- Filterbag FBV 11/14 HEPA
- Carry handle with lockable cable hook
- Parking position for floor nozzle
- Accessory storage
- Accessory: suction hose 32-250 TS (incl. handle)
- Ø 32 mm x 2,5 m, 2 x suction tube aluminium TS 32-50 (each 50 cm), professional universal nozzle 27 TS (reversible), crevice nozzle 23 TS, upholstery nozzle 10 TS

Model: TS 714 RTS HEPA

Item no.: 017716 | plastic grey



Technical data:

Power consumption (max.):	700 Watt	Sound power level:	73 dB(A)
Volume flow (max.):	42 l/s	Sound pressure level:	62 dB(A)
Vacuum (max.):	210 mbar	Energy efficiency class:	A
Container volume (max.):	14 l	Dimensions WxDxH (cm):	40 × 29 × 40.5
Power cable length:	10 m (PVC)	Weight:	4.9 kg

Certification mark TS 714 RTS HEPA



Power regulation

For efficient dirt collection, the suction power can be adjusted continuously to suit any floor covering by means of a control dial.



Accessories

4 accessory slots on the back of the vacuum cleaner as well as lateral parking positions for nozzles allow comfortable transport. The cable hook ensures secure fastening of the power cable.



Agile and economical

Broom haaga 137 accu

The commercial battery sweeper, ideal for cleaning in between. With ergonomic handle, rubberized wheels and sweeping roller and two side brushes, for thorough cleaning to the corners.

Ready to use without socket

Spacesaving to store in the corner, always ready to use in any situation.



Accessories included

In addition to a battery pack (10.8 V / 2.0 Ah) and the quick charger with power supply, an additional set of side brushes is included.



Areas of application:



haaga 137 accu

Features :

- Rubberized wheels
- Large handle
- Telescopic handle with stepless height adjustment
- Lithium-ion battery
- Quick charger with power supply
- Side brooms
- Roller brush
- ON / OFF footswitch

Model: haaga 137 accu
Item no.: 020297 | Kunststoff grau

Technical data:

Sweeping width:	37 cm	Battery voltage V /Ah:	10,8/2,0
Sweeping capacity:	1.225 m ² /h	voltage V / Hz:	100-240 / 50/60
Container volume (max.):	2 l	Sound level:	63 dB (A)
Running time (max.):	ca. 45 Min.	Dimensions W xD xH:	30 x 37 x 11 cm
Charging time:	ca. 90 Min.	Weight:	2,8 kg

Hand dryers, hair dryers, accessories.

Simple, Safe, Stylish

Simple symbols, which are briefly explained below, guide you through our complete program. If you have further questions, please contact us, we look forward to hearing from you.

Explanation of pictogram:



Officially approved



Environmentally friendly 100 % recyclable!



The cost-efficient system!



Eco-friendly!



starmix ECO-Line energy saving, cost saving



starmix ECO-Line Plus extreme energy-saving

Explanation of areas of application for starmix products:



For public toilets (airports, railway stations, exhibition halls, etc.)



For industrial plants



For campsites, holiday apartments and holiday cottages



For children and wheelchair users (adjustable height)



For swimming pools and thermal baths (public and private)



For saunas and spas



For sports facilities and fitness clubs



For hotels and restaurants



For offices and schools

Memberships:



Electric Handdryer Association

starmix is a founding member of the electric Handdryer Association. The association is committed to education and fact-based argumentation on the subject of hand dryer hygiene.

Facts, studies and the latest developments concerning the eHA can be found at: <https://handdryerassociation.org/>

Hand dryers, hair dryers, accessories, vacuum cleaner.

Tested and approved

In addition to a multi-stage in-house inspection, our products also meet the official requirements of the test institutes.

Explanation of certification mark:



VDE certification mark (association for electrical engineering, electronics, information technology). The VDE certification mark stands for the safety of a product with respect to electrical, mechanical, thermal, toxic, radiological and other hazards.



Tested safety. Devices must meet the generally accepted technology regulations and comply with the device safety regulations.



The product meets the requirements of the German device and product safety legislation.



Test seal for electromagnetic compatibility.



Norwegian certification mark, enjoys worldwide recognition as proof of compliance with relevant safety and EMC standards.



Protection-insulated housing (protection class II). Appliance requires no protective conductor.

IPX1

Protection against water drops that fall vertically.

IP33

Protection against penetration with tool (probe 2.5mm Ø), Solid foreign bodies with a Ø 2.5 mm. Protection against spray water.

IP20

Protection against penetration of solid foreign bodies with a Ø > 12.5 mm.

IP22

Protection against penetration of foreign bodies Ø > 12 mm. Protection against diagonally falling water (water drops), 15 ° in relation to normal operating position.

IP23

Protection against penetration of foreign bodies Ø > 12 mm. Protection against spray water, up to 60 ° compared to normal operating conditions.

IP24

Protection against penetration of foreign bodies Ø > 12 mm. Protection against splashing water from all directions.

IP34

Protection against penetration of foreign bodies Ø > 2.5 mm. Protection against splashing water from all directions.



The certification is compulsory for a variety of products, based on the safety test (IEC standards with Russia-specific deviations).



With the CE marking (Conformité Européenne) the manufacturer confirms the conformity of the product with the applicable EC directives and compliance with the „essential requirements“ defined therein.



Volume measured according to DIN EN 60704-1 and DIN EN 60704-2-1 (according to the enveloping surface method).



Intertek is a worldwide leading company when it comes to testing, inspecting and certifying electric and gas-powered products.

Zertifikate / Auszeichnungen:



HACCP international (Hazard Analysis Critical Control Points). The HACCP certification systematically determines all factors that represent a potential health risk to consumers. This allows the avoidance of health risks or the reduction of such risks to an acceptable level. The certification is relevant to all sectors of the food industry and its suppliers.



Neutral test mark of TÜV Rheinland. Products are tested on a selected individual aspect, depending on the product and the legal framework. Products in the starmix range that bear the LGA logo have been tested for safety.



TopHotel StarAward is based on an independent survey of TopHotel readers. The labelled products have been awarded the bronze StarAward in the "Efficiency" category.

Vacuum cleaners, hand dryers & more.

High tech, high power, high end

As a business in the cleaning sector, you and your employees do a great job maintaining cleanliness every day. And as a responsible host, you make sure that all the equipment in the washrooms of your hotel or restaurant is maintained at a high quality. Our vacuum cleaners for tradesmen, industrial use and cleaning business use and our pump vacuum cleaners as well as our hand dryers and hair dryers are true stars in their respective sectors and do a sound job.



DOWNLOAD THE
CATALOGUE!
www.starmix.de/en



starmix for the hotel:

Sales hospitality

Alejandro Ponce Steiner
Telephone +49 (0) 7163/9988-182
Mobile +49 (0) 174/3215945
Email steiner@starmix.de

starmix for the cleaning:



ELECTROSTAR GmbH

Hans-Zinser-Str. 1-3
D-73061 Ebersbach/Fils
Phone +49 (0) 7163/9988-100
Telefax +49 (0) 7163/9988-013
info@starmix.de

Note DSGVO:

Printed links and QR codes are forwarded to the starmix website and partly to the website of third party providers (eg youtube). The links were checked and classified as harmless at the time of catalog printing. Further information under starmix.de/en/data-protection

Export sales sanitary

Phone +49 (0) 7163/9988-120
Telefax +49 (0) 7163/9988-136
infoe@starmix.de

Visit us on Social Media



Find us on
Facebook



LinkedIn



YouTube



Instagram



You can find more
informationen at
www.starmix.de/en/sanitary

